

8 7 6 5 4 3 2 1

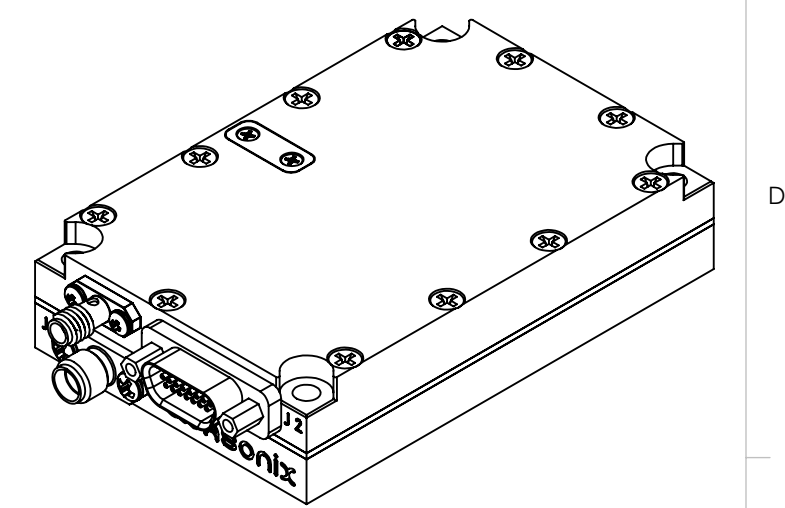

MOUNTING HARDWARE	TIGHTENING TORQUE	CLAMPING FORCE
#6 (MINIMUM 3/4" SCREW LENGTH)	9.6 IN-LB +/- 10%	380 LB +/- 10%

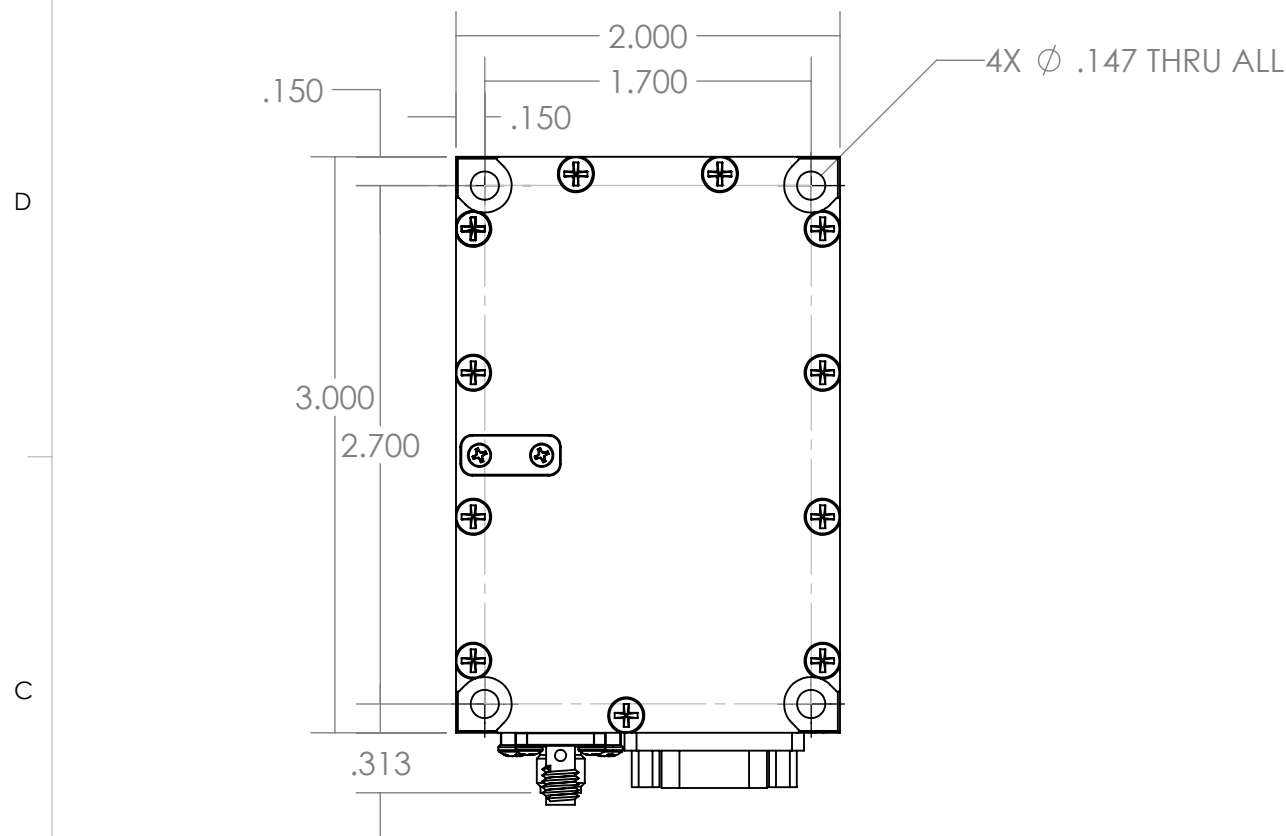
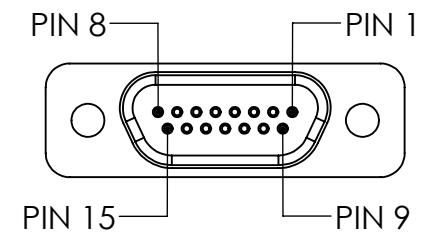
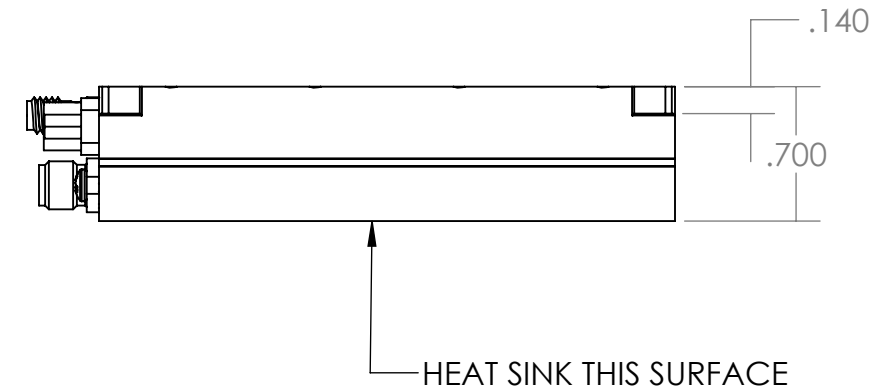
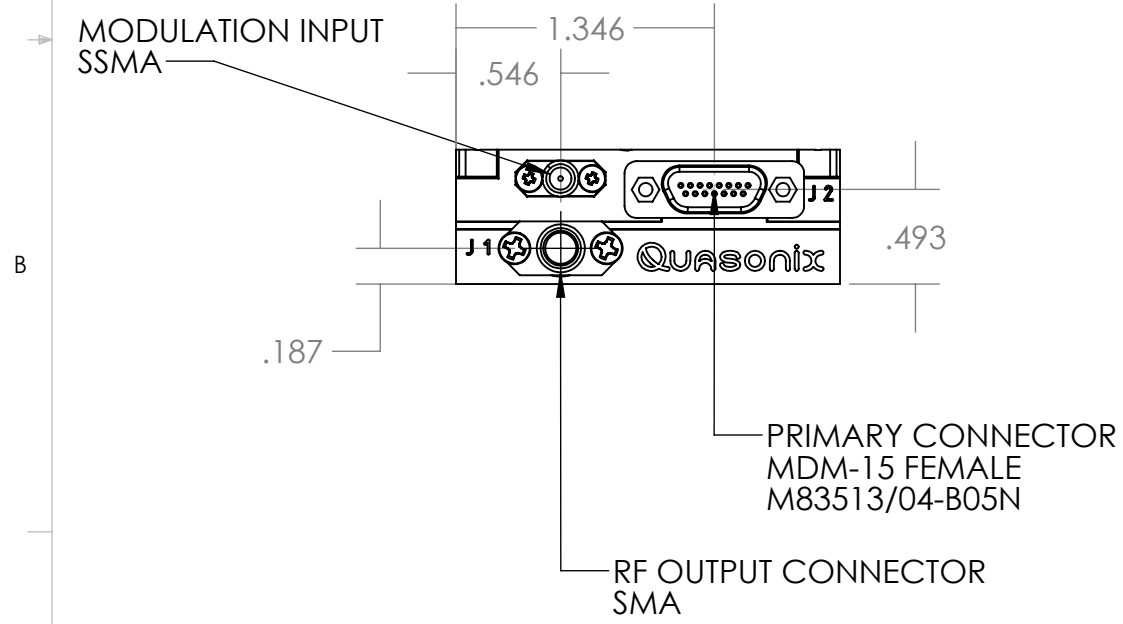

POWER LEVEL	WEIGHT
1 W - 20 W	4.30 OZ
25 W	6.12 OZ

**PROPRIETARY AND CONFIDENTIAL**  
THE INFORMATION CONTAINED IN THIS DRAWING IS THE SOLE PROPERTY OF QUASONIX INC. ANY REPRODUCTION IN PART OR AS A WHOLE WITHOUT THE WRITTEN PERMISSION OF QUASONIX INC. IS PROHIBITED.

UNLESS OTHERWISE SPECIFIED:		NAME	DATE
DIMENSIONS ARE IN INCHES		DRAWN	NFE 7/24/14
TOLERANCES:		CHECKED	
ANGULAR: MACH ±1 BEND ±1		ENG APPR.	
TWO PLACE DECIMAL ±0.01		MFG APPR.	
THREE PLACE DECIMAL ±0.003		Q.A.	
INTERPRET GEOMETRIC TOLERANCING PER:		COMMENTS:	
MATERIAL			
FINISH			
NEXT ASSY	USED ON		
APPLICATION			

TITLE: 04AA		
SIZE <b>B</b>	DWG. NO. QSX-TX-04AA	REV A
SCALE: 1:1	WEIGHT: ABOVE SHEET 1 OF 1	

8 7 6 5 4 3 2 1