

# **PERFORMANCE OF SOQPSK AND MULTI-H CPM IN THE PRESENCE OF ADJACENT CHANNEL INTERFERENCE**

**Terrance J. Hill**

**Nova Engineering, Inc., Cincinnati, OH**

## **ABSTRACT**

Multi-h CPM has been selected as the Tier II waveform for the Advanced Range Telemetry (ARTM) program, because it offers 50% better spectral efficiency than Feher-patented FQPSK, which is the Tier I waveform. Shaped Offset QPSK has been shown to be nearly identical in performance to Feher-patented FQPSK. Both the Tier I and Tier II waveforms must operate in the presence of adjacent channel interference in order to meet the range community's telemetry requirements. This paper presents an experimental characterization of SOQPSK and Multi-h CPM in the presence of adjacent channel interference, over a range of channel spacings and differential signal amplitudes. Quantitative results are presented which demonstrate the relative robustness of the ARTM Tier I and Tier II waveforms, with adjacent channel interference representative of a typical range environment.

## **KEY WORDS**

Shaped Offset QPSK, FQPSK, SOQPSK, Multi-h CPM, Adjacent Channel Interference

## **INTRODUCTION**

The objective of the Advanced Range Telemetry (ARTM) project is to find means of transmitting more telemetry data in less bandwidth, including, among other approaches, the development of spectrally efficient modulation techniques. Feher-patented FQPSK has been adopted as the Tier I ARTM waveform because it offers approximately twice the data capacity of traditional PCM/FM in the same bandwidth. Offering even greater data capacity than FQPSK, multi-h CPM has been selected as the ARTM Tier II waveform.

The claimed increases in data capacity afforded by these new modulation techniques are often inferred by comparing their power spectral density (PSD) to that of PCM/FM. While the PSD is a useful guide to spectral efficiency, it is not a complete description of the system performance. For example, receiver selectivity plays a significant role in ameliorating interference from adjacent channels, but it clearly cannot be assessed from a measurement of the signal spectrum. Because some modulation techniques are more tolerant of "tight" filtering than others, it is important to include the effect of receiver filtering on the overall link performance (this is quantified later in this paper). In a similar vein, adjacent channel interference can cause carrier recovery loops and symbol synchronizers to exhibit increased jitter, but once again, not all modulations are equally affected by these types of impairments.

Since the PSD is a characterization of only the transmit end of the link, but overall performance depends upon the behavior of the receiver and demodulator as well, spectrum managers are better served by a complete assessment of the entire link. Ultimately, this information is used to determine what minimum channel spacing is required to maintain acceptable BER performance. Our objective in this paper is to determine the required channel spacings for these waveforms by measuring the effect of adjacent channel interference on BER.

## WAVEFORM DEFINITIONS

As stated above, Feher-patented FQPSK is the ARTM Tier I waveform, and it would be desirable to include FQPSK results in the present paper. Unfortunately, FQPSK is a proprietary modulation whose details are not known to the author. However, Shaped Offset QPSK (SOQPSK) has been previously shown [1, 2, 3, 4] to be nearly identical to, and interoperable with, FQPSK. Consequently, we will use SOQPSK as representative of the Tier I waveform, for the results presented here.

SOQPSK describes a family of constant-envelope modulations, all of which are a derivative of, and interoperable with, the SOQPSK waveform defined in MIL-STD-188-181 and 188-182. In general terms, all members of the SOQPSK family can be thought of as offset QPSK, modified so that the 90-degree phase transitions are smooth, and always on the unit circle.

While the ARTM Tier I modulation occupies approximately half the bandwidth of the ubiquitous PCM/FM waveforms, the multi-h CPM Tier II waveform collapses the spectrum even further, to approximately one-third of PCM/FM. The Tier II modulation has been previously defined and analyzed in [5]. Like SOQPSK, multi-h CPM is a very large family of modulations. Our analysis

here is restricted to the  $M=4$ ,  $3RC$ ,  $h = 4/16, 5/16$  version described in [5]. The power spectral densities of the relevant modulations are presented in Figure 1.

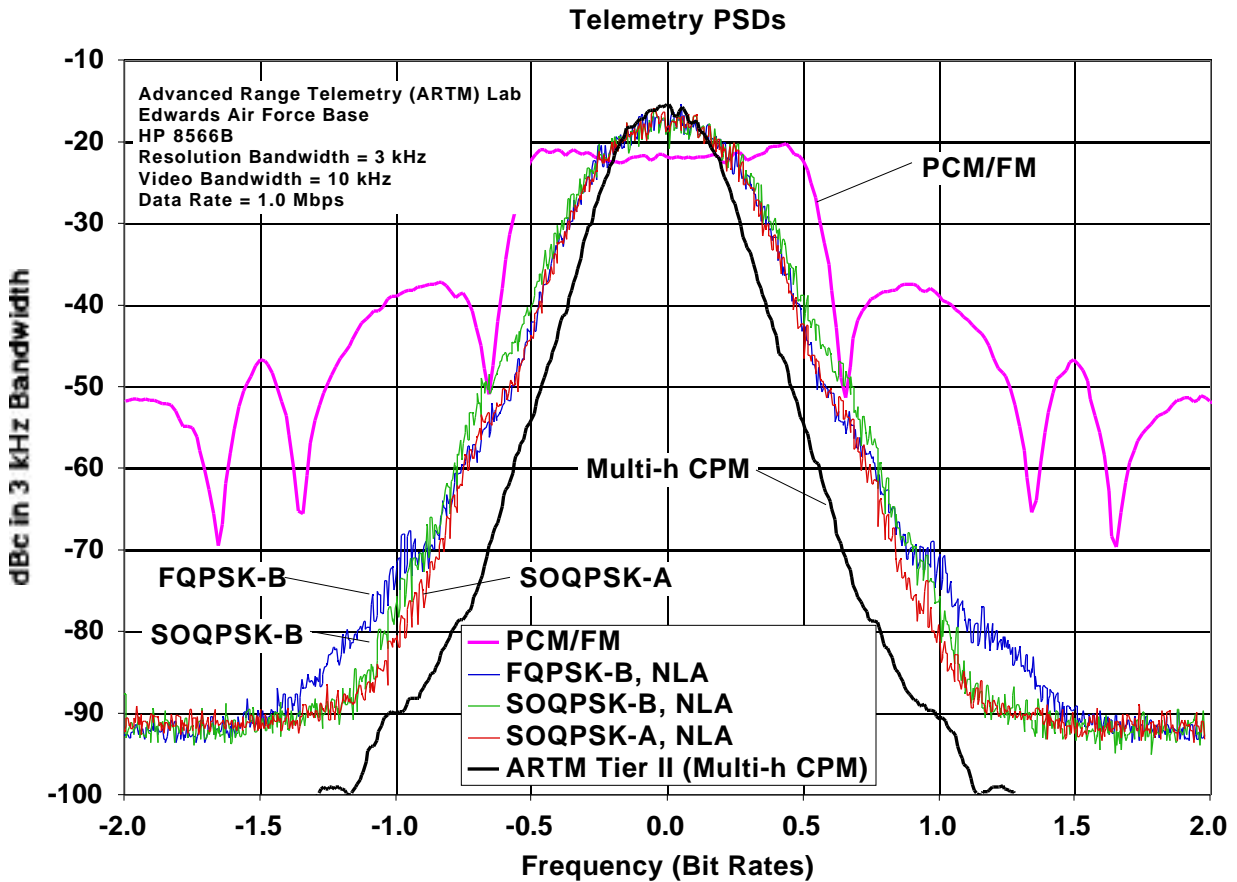

Figure 1. Power Spectral Density for various telemetry modulations.

It should be pointed out that all of the modulations in Figure 1, except for FQPSK-B, are constant envelope waveforms. Consequently, the linearity of the power amplifier in the transmitter is of no concern, except for FQPSK. The results for FQPSK-B, SOQPSK-A, and SOQPSK-B shown in Figure 1 include the effect of a non-linear test amplifier from the ARTM laboratory, which causes some spectral regrowth for FQPSK.

### EXPERIMENTAL TECHNIQUE

A block diagram of the test configuration is depicted in Figure 2. The first stage of testing is performed with the adjacent channel interferers turned off. This yields the baseline BER performance of the transmitter / receiver combination. The adjacent channels are then turned on at either 0 dB, 10 dB, or 20 dB relative to the desired channel, and offset equally in frequency on each

side of the desired. A BER curve is taken, the frequency separation between the desired and the interferers is reduced, and the BER data collected again. This process of packing the channels more closely together continues until the BER performance has degraded significantly.

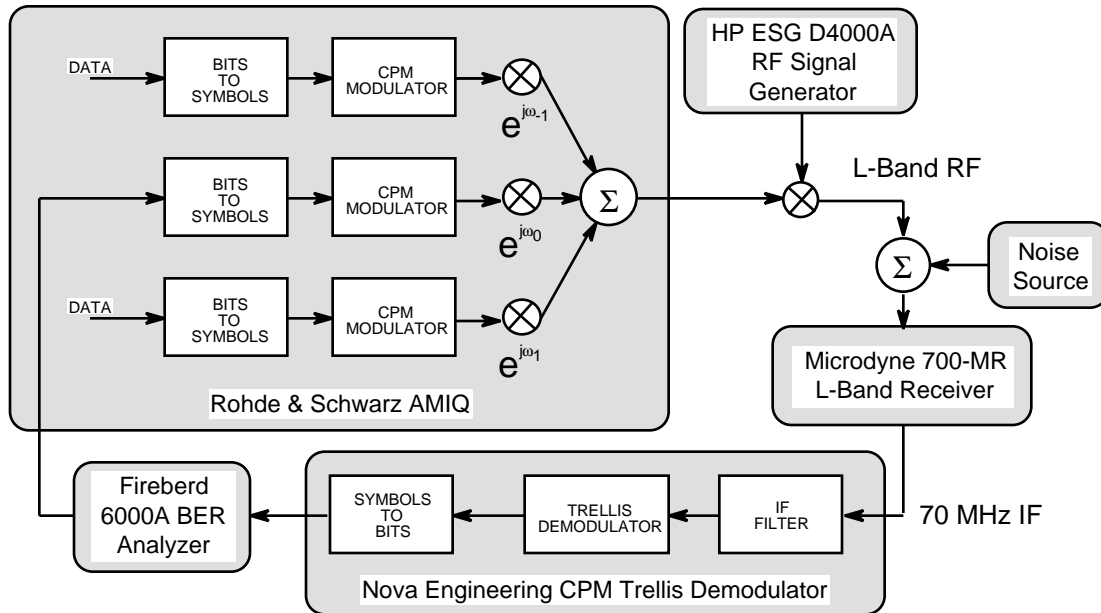
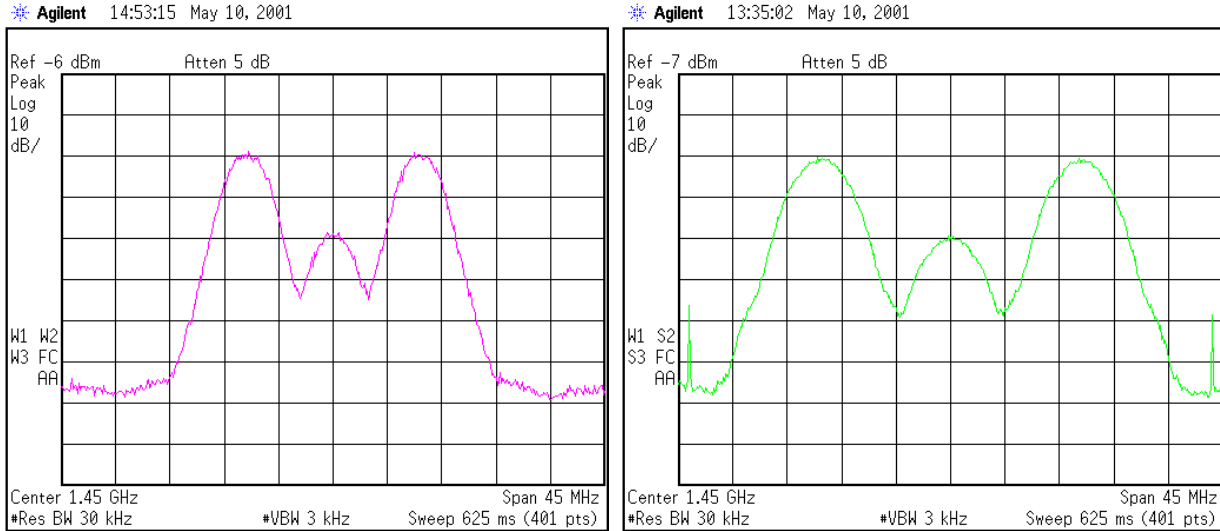

Figure 2. Experimental Test Configuration.

## LABORATORY MEASURED RESULTS

The experimental setup shown in Figure 2 was utilized to gather data for multi-h CPM (ARTM Tier II waveform) and both SOQPSK-A and SOQPSK-B (which are highly similar to FQPSK, the Tier I waveform). Representative power spectral densities for three channels of 9 Mbps multi-h CPM and SOQPSK-A are shown in Figures 3 and 4, respectively.

As stated earlier, some modulations are more tolerant of "tight" IF filtering in the receiver than others. This is exemplified in Figure 5, which shows the detected constellations for both SOQPSK-A and SOQPSK-B, with two different IF filter bandwidths. The "wide" IF filter is 2.2 times the bit rate, while the "narrow" IF is 0.55 times the bit rate. From these constellation diagrams, one might judge that SOQPSK-A would exhibit slightly poorer BER performance than SOQPSK-B, with either IF filter. Further, because of the significant dispersion of the SOQPSK-A constellation with the narrow IF, one would expect the narrow filtering to cause greater degradation in BER performance for SOQPSK-A than for SOPQSK-B.



Figures 3 (left) and 4( right). PSD of 9 Mbps multi-h CPM with adjacent channel spacing of 0.8 times the bit rate, and 9 Mbps SOQPSK-A with adjacent channel spacing of 1.2 times the bit rate.

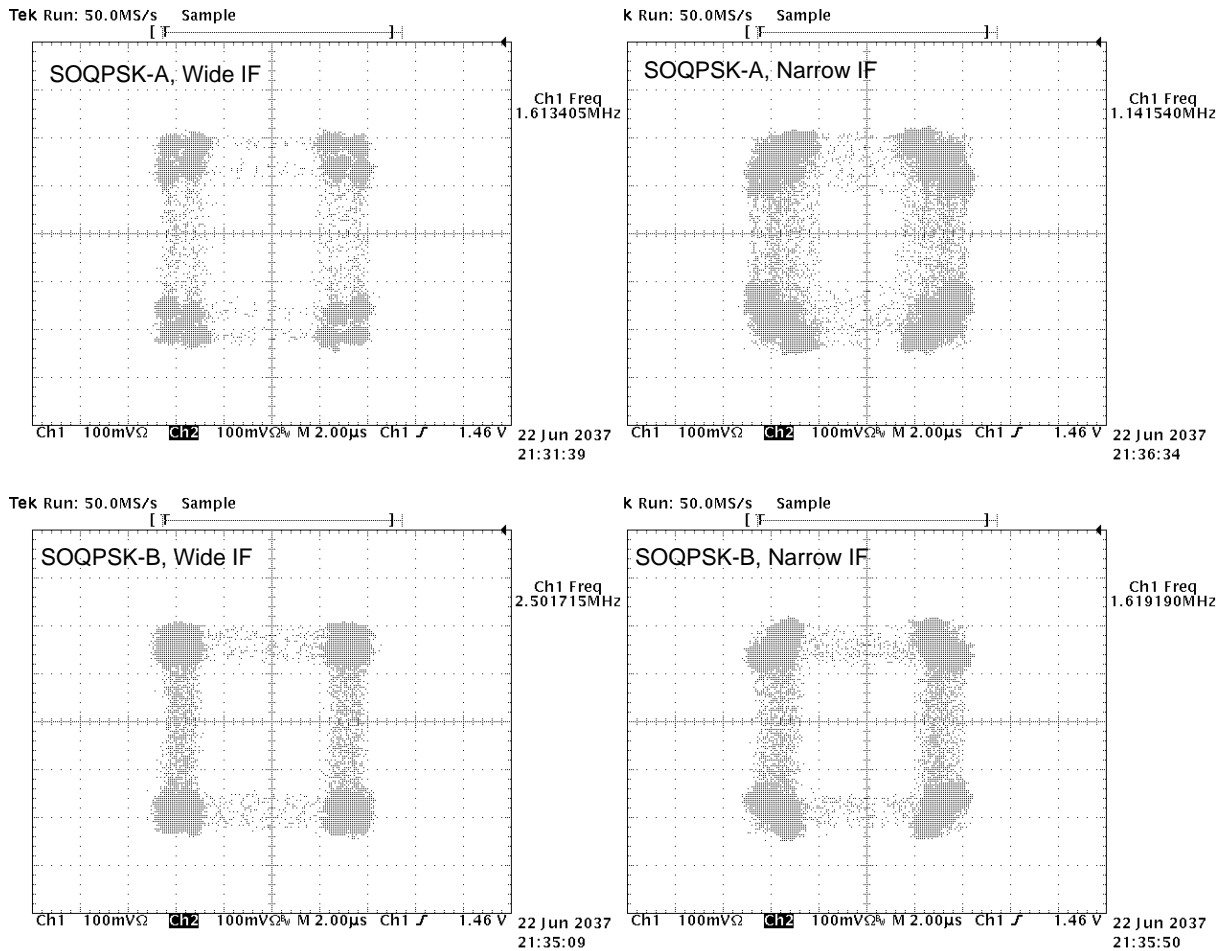

Figure 5. Detected constellations for SOQPSK-A and -B, with wide and narrow IF filters.

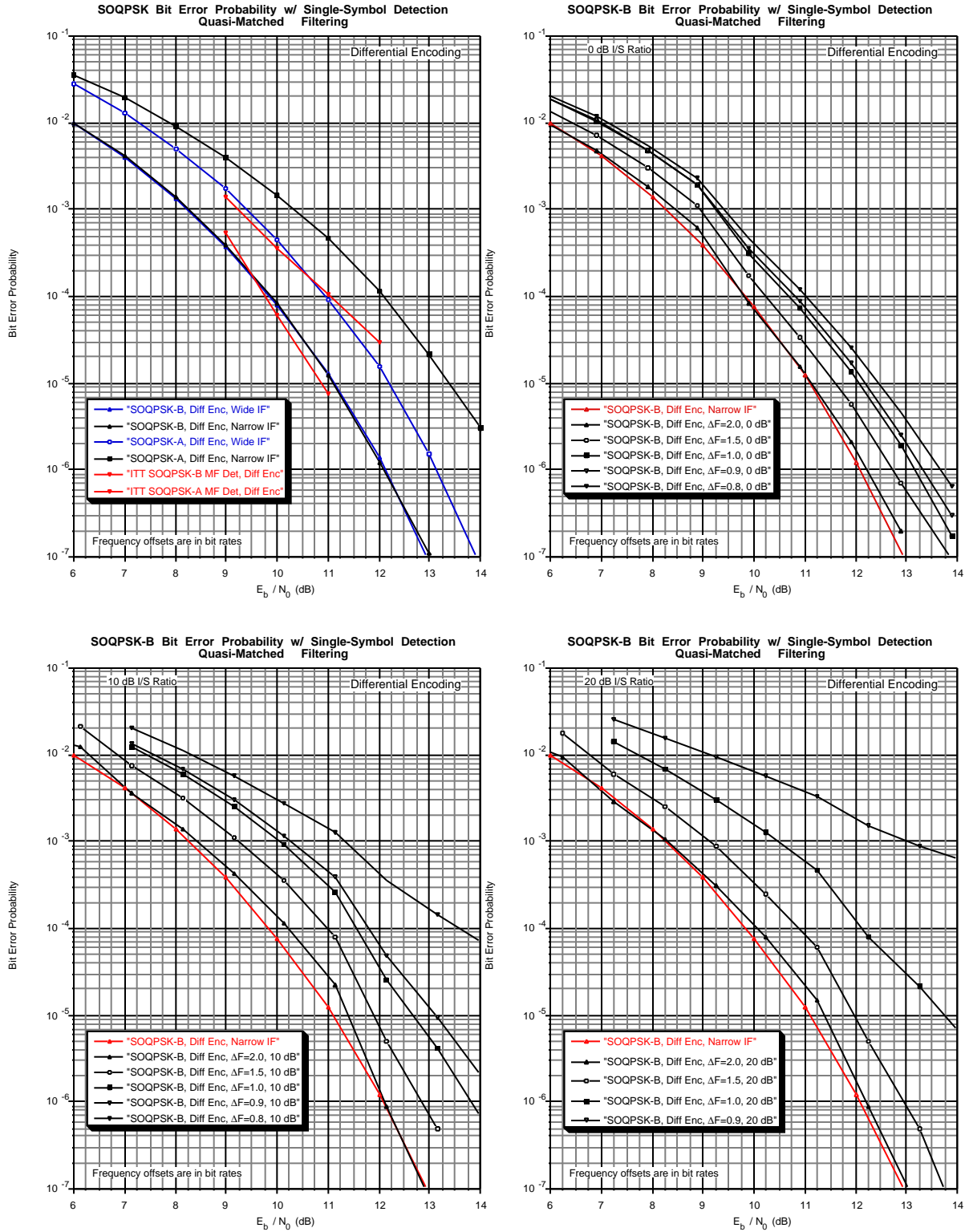

Figure 6. BER results for SOQPSK-B. Upper left is without ACI. Remaining three plots are with adjacent channels at interference / signal ratios of 0 dB, 10 dB, and 20 dB.

The BER curves in the upper left of Figure 6 show that these are exactly the measured effects. With the wide IF, SOQPSK-B is approximately 1 dB better than SOQPSK-A. Furthermore, we see that SOQPSK-B is virtually unaffected by the narrow IF filtering, while SOQPSK-A degrades by about 1 dB relative to the wide IF case. In addition to the laboratory results for both SOQPSK-A and -B, Figure 6 also incorporates the simulation results from [2]. Because the experimental hardware employs differential encoding, but the simulated error rates in [2] do not, we have doubled the simulation error rate to make them more directly comparable.

Figure 6 also shows the BER performance of SOQPSK-B with interference ratios of 0 dB, 10 dB, and 20 dB. From this figure, we see that with an I/S ratio of 20 dB, adjacent channels separated by 1.5 bit rates from the desired will degrade performance by about 1 dB at BER = 1.0e-5.

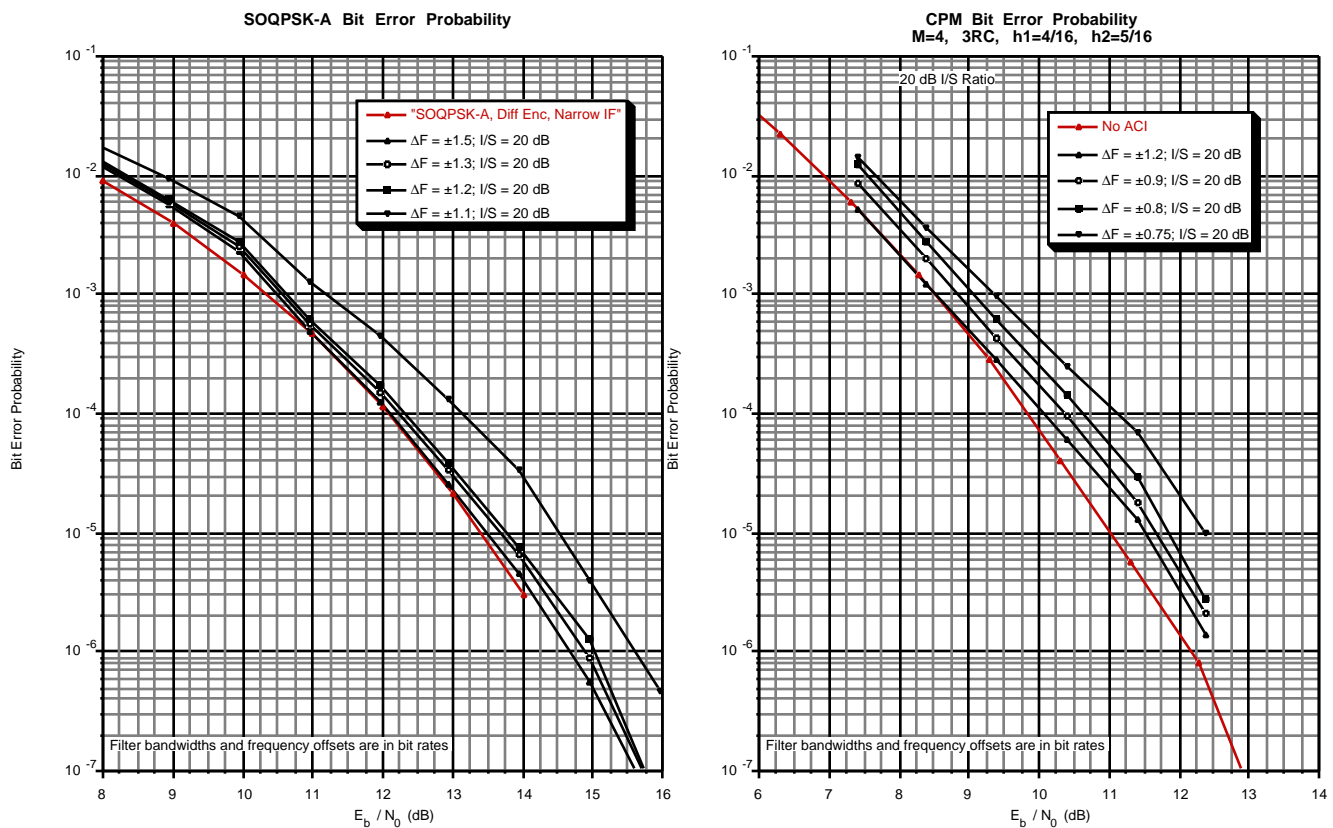

Figure 7. BER results for SOQPSK-A and multi-h CPM.  
 Three channels at 20 dB interference / signal ratio.

Figure 7 (left) depicts the performance of SOQPSK-A, with an I/S ratio of 20 dB. Note that the 1 dB degradation from baseline (no interference) performance is reached with the adjacent channels offset by approximately 1.11 times the bit rate. This closer spacing (than SOQPSK-B) is undoubtedly due to the narrower spectrum of the -A version. However, it must be pointed out that, although 1 dB

degradation is not incurred until the spacing is reduced to approximately 1.11 bit rates, the absolute detection efficiency at this point is 2.5 dB poorer than SOQPSK-B (BER = 1.0e-5 at  $E_b/N_0 = 14.5$  dB for SOQPSK-A, versus 12.0 dB for SOQPSK-B).

The BER performance of multi-h CPM in the presence of adjacent channels 20 dB above the desired is also shown in Figure 7 (right). Here the 1 dB degradation point (at 1.0e-5) is reached at a channel spacing of approximately 0.77 times the bit rate, which is nearly one-half of the spacing required for SOQPSK-B.

It is worth noting that these results are valid regardless of any non-linearity in the power amplifier, since CPM (and SOQPSK) are constant envelope waveforms. This is in contrast to Feher-patented FQPSK which exhibits a slight amount of amplitude modulation, and therefore experiences sideband regeneration which varies according to the AM-AM and AM-PM behavior of the amplifier.

### SUMMARY

The table below summarizes the results for SOQPSK-A, SOQPSK-B, and multi-h CPM. It is clear that CPM offers substantially more data capacity in a given bandwidth than either variant of SOQPSK. While SOQPSK-A allows for closer channel spacing than SOQPSK-B, this increased capacity comes at the expense of approximately 2.5 dB in detection efficiency.

Modulation	Channel spacing for 1 dB loss at I/S ratio = 0 dB	Channel spacing for 1 dB loss at I/S ratio = 10 dB	Channel spacing for 1 dB loss at I/S ratio = 20 dB	$E_b/N_0$ for BER = 1.0e-5, with I/S ratio = 20 dB
SOQPSK-A	-	-	1.11 bit rates	14.5 dB
SOQPSK-B	1.0 bit rates	1.4 bit rates	1.50 bit rates	12.0 dB
Multi-h CPM	-	-	0.77 bit rates	12.0 dB

### CONCLUSIONS

The objective of the ARTM project is to develop methods of getting more telemetry through less bandwidth. More specifically, the goal of the Tier II waveform, multi-h CPM, is to carry 1.5 times as much data as the Tier I waveform (FQPSK-B) in the same bandwidth. While we have not analyzed the proprietary FQPSK-B waveform, the results provided here demonstrate that this goal is probably met. We have shown that multi-h CPM provides 1.44 times the data capacity of SOQPSK-A and nearly double the capacity of SOQPSK-B. If the arbiter of "acceptable" performance is



expressed in terms of absolute detection efficiency, rather than degradation relative to an interference-free baseline, then the comparison favors multi-h CPM even more strongly. This is because although SOQPSK-A allows closer channel spacing than SOQPSK-B, SOQPSK-A achieves this advantage at a cost in absolute detection efficiency of 2.5 dB. Multi-h CPM and SOQPSK-B have nearly identical detection efficiency, but multi-h CPM provides almost twice the capacity of SOQPSK-B.

### **ACKNOWLEDGEMENTS**

The author would like to acknowledge the support of Mark Geoghegan and Kevin Hutzler of Nova Engineering for the design of the experimental setup, and the collection and analysis of the experimental data.

### **REFERENCES**

- [1] Hill, Terrance J., "An Enhanced, Constant Envelope, Interoperable Shaped Offset QPSK (SOQPSK) Waveform For Improved Spectral Efficiency", 00-02-5, Proceedings of International Telemetry Conference, San Diego, CA, October 2000.
- [2] Younes, Badri; Brase, James; Patel, Chitra; Wesdock, John, "An Assessment of Shaped Offset QPSK for Use in NASA Space Network and Ground Network Systems", Meetings of Consultative Committee for Space Data Systems, Toulouse, France, October 2000.
- [3] "Draft Recommendations For Space Data System Standards, Radio Frequency And Modulation Systems, Part 1, Earth Stations And Spacecraft", CCSDS 401.0-R-F2000, November 2000, <http://ccsds.gst.com/review/RPA101/401rF2K.pdf>
- [4] Simon, Marvin, "Bandwidth Efficient Digital Modulation with Application to Deep Space Communications," to be published as part of the JPL Deep Space Communications and Navigation (DESCANSO) Monograph Series, 2001.
- [5] Geoghegan, Mark, "Description and Performance Results for the Advanced Range Telemetry (ARTM) Tier II Waveform ", 00-02-1, Proceedings of International Telemetry Conference, San Diego, CA, October 2000.