

# **BANDWIDTH AND POWER EFFICIENCY TRADE-OFFS OF SOQPSK**

**Mark Geoghegan**  
Nova Engineering Inc., Cincinnati, OH

## **ABSTRACT**

Shaped Offset QPSK (SOQPSK), as proposed and analyzed by Terrance Hill, is a family of constant envelope waveforms that is non-proprietary and exhibits excellent spectral containment and detection efficiency. Results for two variants, defined as SOQPSK-A and -B, have previously been presented. However, it remains to be seen whether or not even more attractive choices exist. This paper explores the bandwidth and power efficiency trade-offs of the entire SOQPSK family using computer simulations and analytical performance bounds.

## **KEY WORDS**

SOQPSK, Spectral Efficiency, Power Efficiency, Bandwidth/Efficiency Plane

## **INTRODUCTION**

SOQPSK is a non-proprietary modulation technique that is quickly gaining popularity in both terrestrial and space applications. The family of SOQPSK waveforms, as described by Hill [1], are constant envelope signals with excellent spectral containment and detection efficiency. Performance results for two variants, namely SOQPSK-A and -B, were presented. In addition to Hill's paper, analytical performance bounds of the optimal detector for SOQPSK have been published [2] as well as performance results using integrate and dump and third order Butterworth detection filters that are representative of current NASA ground and space OQPSK demodulator equipment [3]. Although the performance of the two variants is very impressive, it is unknown whether or not they are the 'best' in this family of waveforms. The objective of this paper is to investigate the power and bandwidth efficiency trade-offs attainable with Hill's SOQPSK family of waveforms. Computer simulations and analytical bounds were used to explore the bandwidth and detection efficiency of individual members as specified by the quadruplet ( $\rho$ , B,  $T_1$ , and  $T_2$ ). The results illustrate possible combinations of power and spectral efficiency attainable from this family of waveforms.

## DESCRIPTION OF SOQPSK

The SOQPSK waveforms described by Hill are constant envelope, continuous phase modulations that allow a designer to easily trade-off spectral and power efficiency by varying a few simple parameters. The waveforms are completely described by either their instantaneous phase or frequency. Figure 1 illustrates a conceptual SOQPSK modulator that maps a binary input stream  $a(i)$  into ternary valued (+1, 0, -1) frequency impulses  $\alpha(t)$ , passes them through a shaping filter with response  $g(t)$ , and applies the instantaneous frequency  $f(t)$  or phase  $\phi(t)$  to an appropriate modulator which produces the desired SOQPSK waveform.

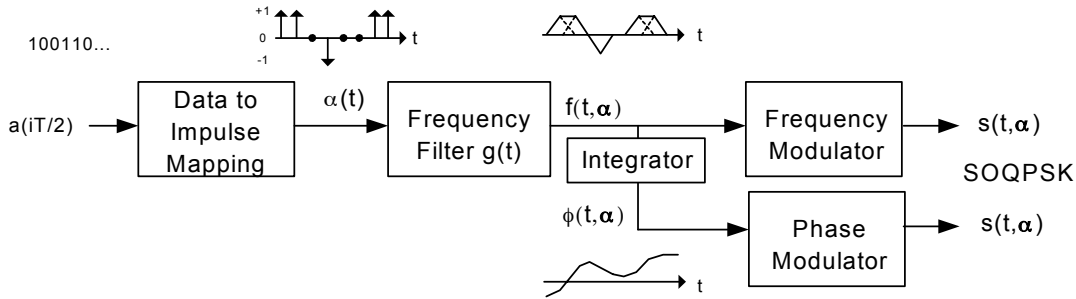

Figure 1. SOQPSK Modulator

The frequency pulse shapes for two variants of SOQPSK, which are called SOQPSK-A and SOQPSK-B, are given by  $g(t) = n(t) * w(t)$ , where

$$n(t) = \frac{A \cos(\pi \rho B t / T_s) * \sin(\pi B t / T_s)}{1 - 4(\rho B t / T_s)^2} \quad w(t) = \left\{ \begin{array}{ll} 1, & \text{for } |t/T_s| < T_1 \\ \frac{1}{2} + \frac{1}{2} \cos \frac{\pi(|t/T_s| - T_1)}{T_2}, & \text{for } T_1 < |t/T_s| < T_1 + T_2 \\ 0, & \text{for } |t/T_s| > T_1 + T_2 \end{array} \right\}$$

Note that  $T_s$  is the symbol period and that the four parameters  $\rho$ ,  $B$ ,  $T_1$ , and  $T_2$  serve to completely define the frequency pulse shapes for SOQPSK-A and SOQPSK-B, as well as an infinite set of similar, and interoperable, waveforms. The specific values for these SOQPSK variants are listed in Table 1 and the resulting pulse shapes and spectra are plotted in Figures 2 and 3. For comparison purposes, MIL-STD-188-182 SOQPSK, which uses a rectangular frequency pulse, is also included. The dramatic reduction in sidelobe energy makes SOQPSK-A and SOQPSK-B very attractive for terrestrial, satcom, and space applications.

Modulation Type	$\rho$	$B$	$T_1$	$T_2$
MIL-STD-188-182	0	0	0.25	0
SOQPSK-A	1.0	1.35	1.4	0.6
SOQPSK-B	0.5	1.45	2.8	1.2

Table 1. SOQPSK Parameters

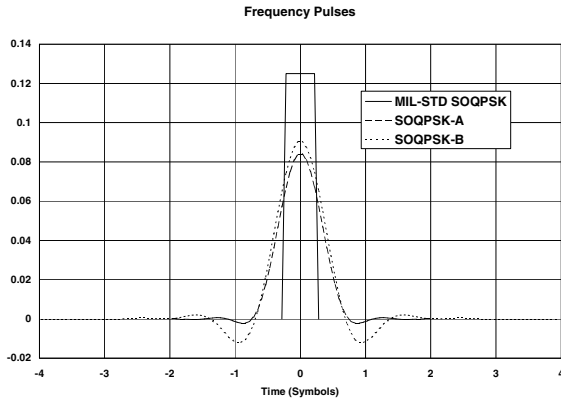

Figure 2. SOQPSK-A,-B Pulse Shapes

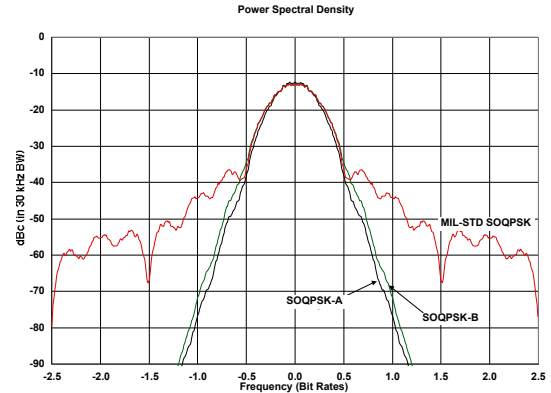

Figure 3. PSD of SOQPSK-A,-B

### BANDWIDTH AND POWER EFFICIENCY CALCULATIONS

For each candidate, a measure of its power and bandwidth efficiency was computed. The bandwidth measurement was defined as the amount of bandwidth required to contain a certain percentage of the total signal power. For example, the 99% bandwidth is defined as the amount of spectrum required to include 99% of the total power in the signal and is equal to the  $-20$  dB point of the fractional out-of-band power. In addition to the 99% bandwidth, the 99.9%, 99.99%, and 99.999% bandwidths were also calculated using the following equation.

$$\%BW = \frac{\int_{-B/2}^{B/2} S(f)df}{\int_{-\infty}^{\infty} S(f)df} \quad \text{where the B is normalized to the bit rate and } S(f) \text{ is the PSD.}$$

The detection performance was evaluated using three detectors. The first detector is the optimum receiver for SOQPSK using the Viterbi algorithm. The detection performance was determined by using an analytical performance bound. It was determined from [2] that by computing the Euclidean distance for the difference sequence  $[-1 \ 0 \ 1]$  and  $[1 \ 2 \ 1]$  a very accurate performance bound could be constructed that agreed extremely well with Monte Carlo simulation results. The bound that was used to compute the bit error probability (BEP) at  $10^{-5}$  for each candidate is shown below.

$$P_{SOQPSK}(e) \approx \frac{1}{4} \operatorname{erfc} \left( \sqrt{\frac{d_{-101}^2 E_b}{2N_o}} \right) + \frac{1}{4} \operatorname{erfc} \left( \sqrt{\frac{d_{121}^2 E_b}{2N_o}} \right)$$

The detection performance of each candidate was also evaluated using traditional linear detectors that sample the output of a linear filter and use a threshold test to make the data decision. Two types of filters were used, an integrate and dump and a third order

Butterworth filter with a 3 dB cutoff frequency equal to the bit rate. These detection filters are representative of conventional OQPSK space and ground demodulator equipment used by NASA [3]. The BEP for the linear filters was computed analytically using the noise-free peak samples out of the detector and the calculated noise variance at the filter output.

Using these performance measures, the SOQPSK family of waveforms was explored over its multi-dimensional parametric range specified by the four parameters ( $\rho$ ,  $B$ ,  $T_1$ , and  $T_2$ ). A block diagram of the evaluation procedure is shown in Figure 4.

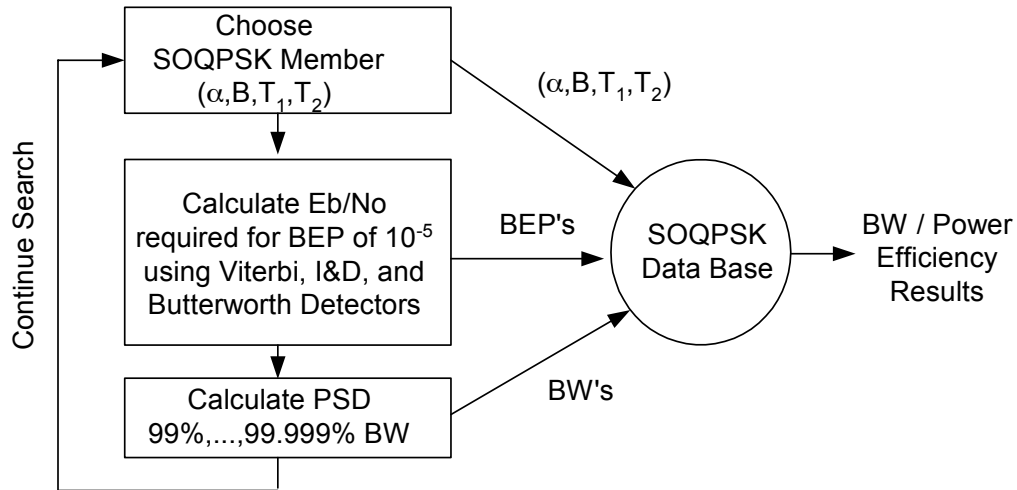

Figure 4. SOQPSK evaluation procedure

## SOQPSK RESULTS

First, a coarse sampling of the parameter space was performed to gain an understanding of how the parameters affected the SOQPSK performance. As results were compiled and analyzed, finer sampling was performed in promising areas. Figures 5, 6, 7, and 8 illustrate the detection efficiency in terms of  $E_b/N_0$  required to achieve  $10^{-5}$  BEP and the 99, 99.9, 99.99, and 99.999% bandwidth requirements with a non-linear amplifier for a Viterbi, Butterworth, and Integrate and Dump detector. Each dot represents the performance of a single SOQPSK variant defined by the quadruplet ( $\rho$ ,  $B$ ,  $T_1$ , and  $T_2$ ). Note that the optimal Viterbi detector performs the best (lowest  $E_b/N_0$  for the same bandwidth) followed by the Butterworth and the integrate and dump filter. In fact, there are SOQPSK variants that, in addition to their high spectral efficiency, outperform theoretical OQPSK in detection efficiency (9.15 versus 9.6 dB for  $10^{-5}$  BEP) when using a Viterbi type receiver. However, one must take into account that the implementation complexity is generally much higher with the Viterbi detector as compared to the linear receiver structures. These curves illustrate the wide range of application for this family of waveforms.

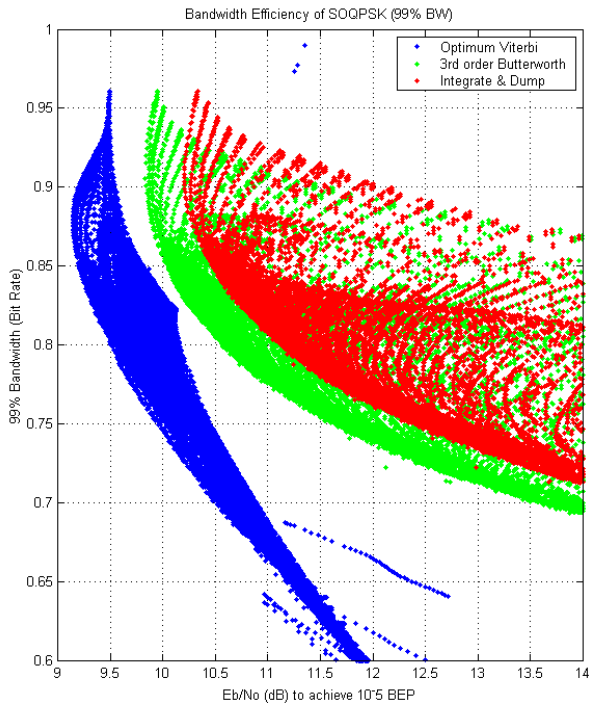

Figure 5. SOQPSK Results with 99% Bandwidth Measure

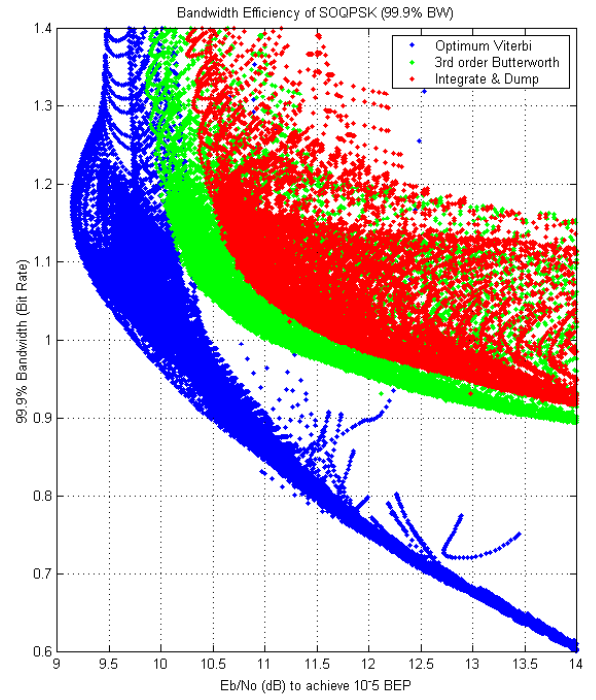

Figure 6. SOQPSK Results with 99.9% Bandwidth Measure

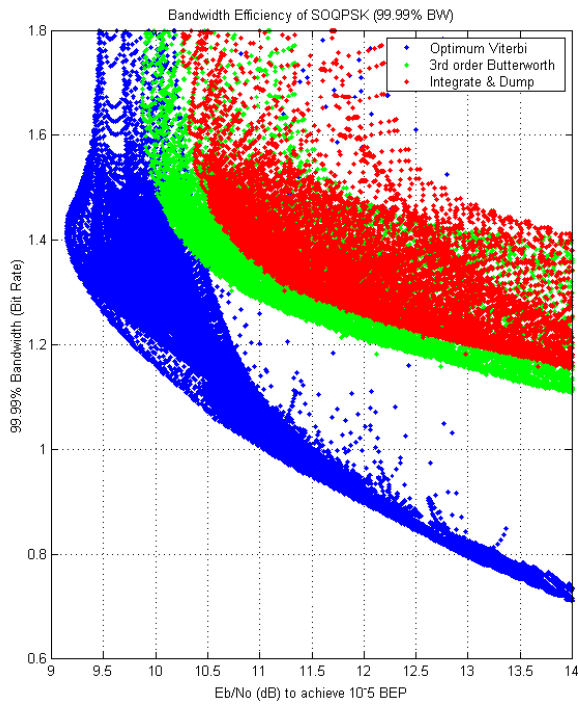

Figure 7. SOQPSK Results with 99.99% Bandwidth Measure

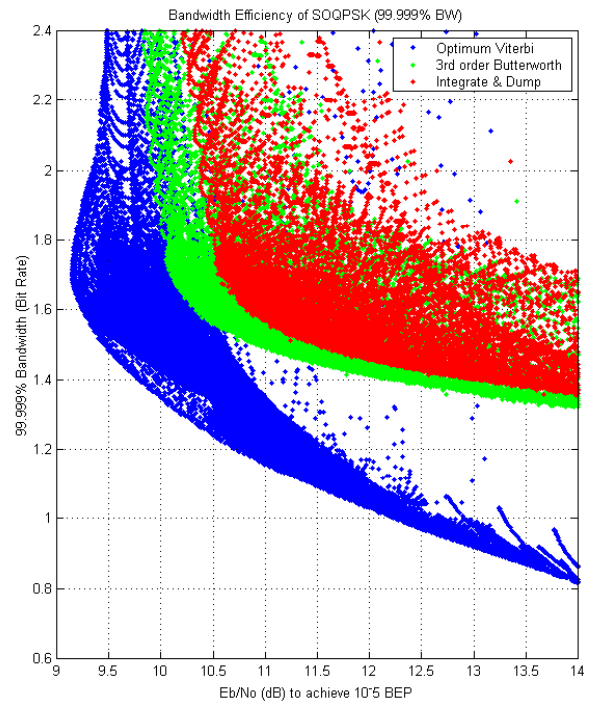

Figure 8. SOQPSK Results with 99.999% Bandwidth Measure

Figure 9 shows the outline of the different detection curves along with the performance of SOQPSK–A, -B and the variant (0.7,1.25,1.5,0.5) for a 99.99% bandwidth measure. This variant will be referred to as SOQPSK-A\* since it requires the same bandwidth as –A but is easier to detect. Table 2 lists the performance of notable variants.

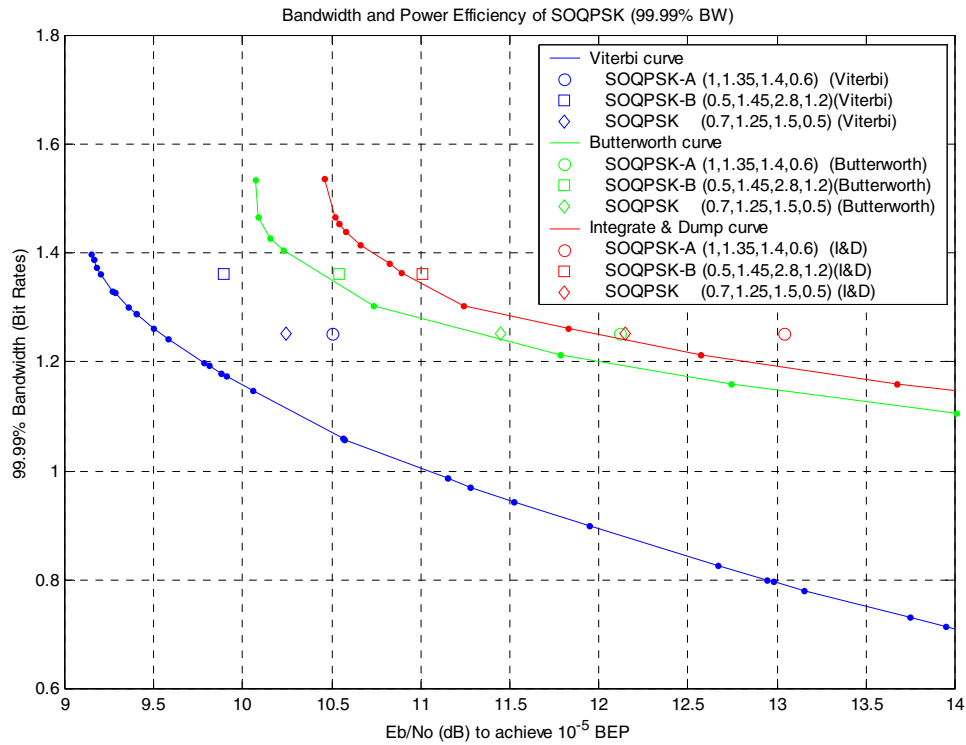

Figure 9. SOQPSK Performance with 99.99% Bandwidth Measure

NOTES	DETECTOR TYPE Eb/No (dB) for BEP = 10 <sup>-5</sup>			99.99% BW with NLA (Bit Rates)	SOQPSK Parameters			
	Viterbi	Butterworth	Int & Dump		$\rho$	B	T <sub>1</sub>	T <sub>2</sub>
SOQPSK-B	9.89	10.54	11.01	1.3620	0.5	1.45	2.8	1.2
SOQPSK-A	10.50	12.12	13.04	1.2523	1.0	1.35	1.4	0.6
SOQPSK-A* Same BW but easier to detect than-A	10.24	11.45	12.15	1.2523	0.7	1.25	1.5	0.5
Good BEP with Viterbi	9.15	13.99	13.96	1.3974	0	1.15	1.739	0
Good BEP with ID and Butterworth	9.63	10.08	10.46	1.5370	0.2	2.05	1.8	0.2

Table 2. Performance Summary of Several SOQPSK variants

Figure 10 shows the out-of-band power versus bandwidth for SOQPSK along with other popular modulations while Figure 11 shows the BEP versus  $E_b/N_0$  performance.

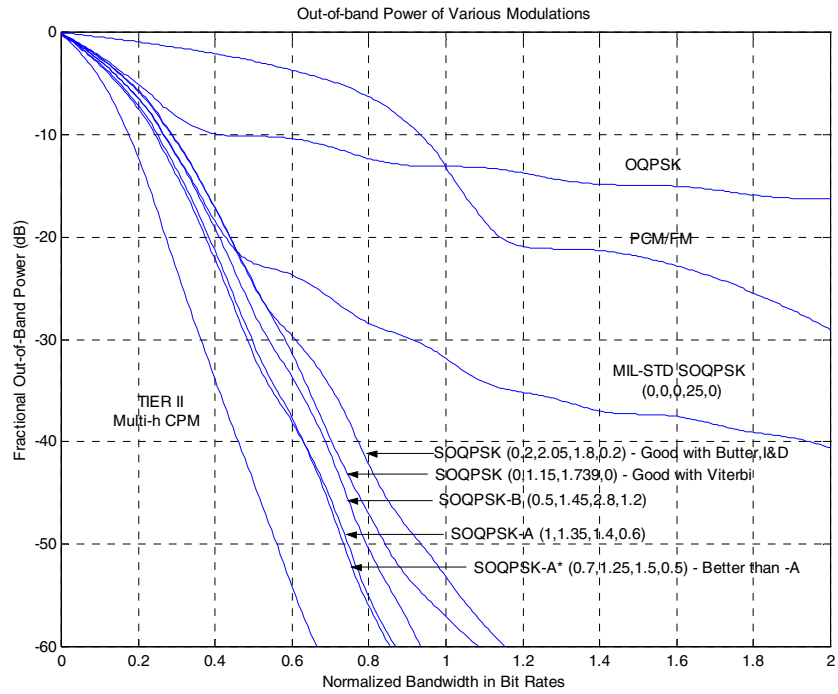

Figure 10. Fractional Out-of-Band Power of Various Modulations

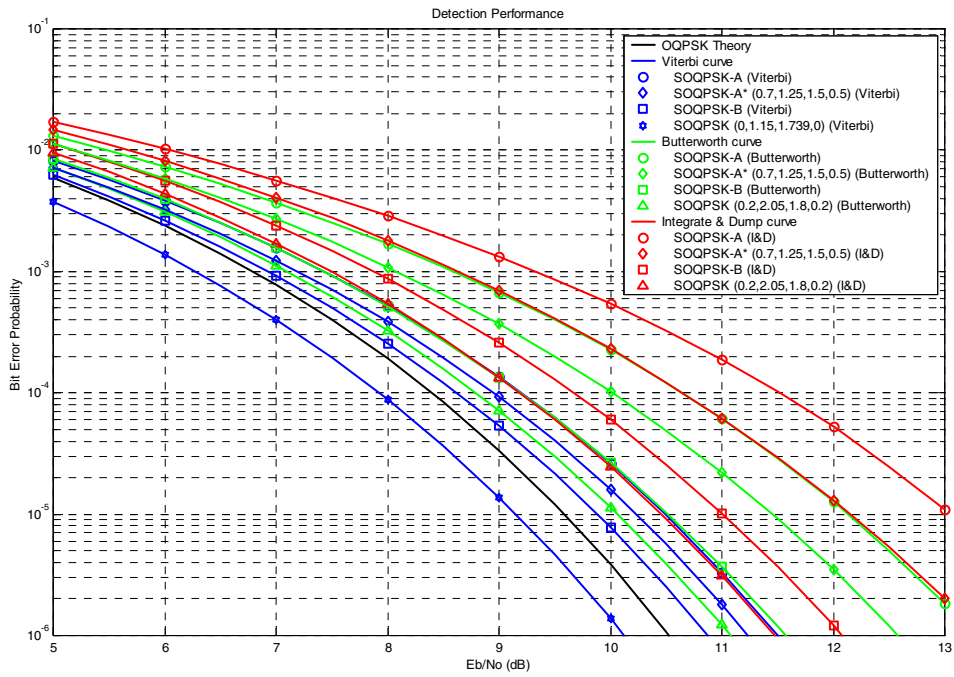

Figure 11. Detection Efficiency for some SOQPSK Variants

Tables 3 lists the performance of several SOQPSK variants. Keep in mind that the variants listed in the table are but a small sampling of the bandwidth and power efficiency trade-offs achievable with the entire SOQPSK family. Notable results include SOQPSK(0,1.15,1.739,0) that has a 99.99% bandwidth of 1.3974R and only requires 9.15 dB to achieve a BEP of 10<sup>-5</sup> with a Viterbi detector. For linear detection, SOQPSK(0.2,2.05,1.8,0.2) works very well with both the Butterworth and integrate and dump detectors (10.07 and 10.47 dB) and is still very bandwidth efficient.

For comparison, Table 4 lists the performance of other telemetry modulations including PCM/FM (with two different non-coherent detectors), GMSK (BT = 0.5 and 0.25), ARTM TIER I Feher patented FQPSK-B, and ARTM TIER II Multi-h CPM. SOQPSK compares very favorably to the GMSK and FQPSK-B waveforms that also have a modulation index of h=0.5. PCM/FM with h=0.7 is more robust but requires roughly twice the bandwidth while the TIER II Multi-h CPM with its h=4/16,5/16 is by far the most spectrally-efficient.

SOQPSK Parameters				Bandwidth 99.99% with NLA (Bit Rates)	DETECTOR TYPE Eb/No (dB) for BEP = 10 <sup>-5</sup>			NOTES
$\rho$	B	T <sub>1</sub>	T <sub>2</sub>		Viterbi	Butter-Worth	Int & Dump	
0	0	0.25	0	3.8681	9.92	12.98	14.1	Mil-Std SOQPSK
1.0	1.35	1.4	0.6	1.2523	10.50	12.12	13.04	SOQPSK-A
0.7	1.25	1.5	0.5	1.2523	10.24	11.45	12.15	SOQPSK-A*
0.5	1.45	2.8	1.2	1.3620	9.89	10.54	11.01	SOQPSK-B
0.0	1.15	1.739	0	1.3974	9.15	13.99	13.96	Best overall detection efficiency.
0.2	2.05	1.8	0.2	1.5737	9.66	10.07	10.47	

Tables 3. Performance of some SOQPSK Modulations

Other Telemetry Modulation Types	Bandwidth 99.99% with NLA (Bit Rates)	DETECTOR TYPE Eb/No (dB) for BEP = 10 <sup>-5</sup>			NOTES
		Viterbi	Linear Filter	Multi-Symbol	
PCM/FM h=0.7,4 <sup>th</sup> order Bessel	2.4	-	11.98	9.3	(Non-Coherent) Significant gain with MSD
GMSK (BT=0.5) [6]	2.08	9.73	-	-	
GMSK (BT=0.25) [6]	1.37	10.3	-	-	BW same as -B but worse detection
Feher Patented FQPSK FQPSK-B	1.26 [4]	10.4 [5]	11.6 [5]	-	ARTM TIER I Waveform
Multi-h CPM (M=4,L=3RC, h <sub>1</sub> =4/16,5/16)	0.913	11.17	-	-	TIER II Waveform

Tables 4. Performance of some other Telemetry Modulations



Figure 12 illustrates a bandwidth/power efficiency diagram using a 99.99% bandwidth measure that includes the effects of a non-linear amplifier (NLA) typically needed to achieve the high efficiency required in telemetry applications. Several other modulation schemes including PCM/FM, GMSK, TIER I Feher patented FQPSK-B, and TIER II Multi-h CPM are included for comparison. From the chart, it is clear that members of the SOQPSK family offer better performance (better detection efficiency with the same bandwidth or less) than either GMSK or FQPSK-B. PCM/FM with the non-coherent multi-symbol detector is robust and has great detection efficiency, but requires nearly twice the bandwidth of the more spectrally-efficient SOQPSK variants. The TIER II multi-h CPM has very good spectral-efficiency and relatively good detection efficiency but requires a quite complex demodulator, as does the narrower SOQPSK waveforms using the Viterbi detector.

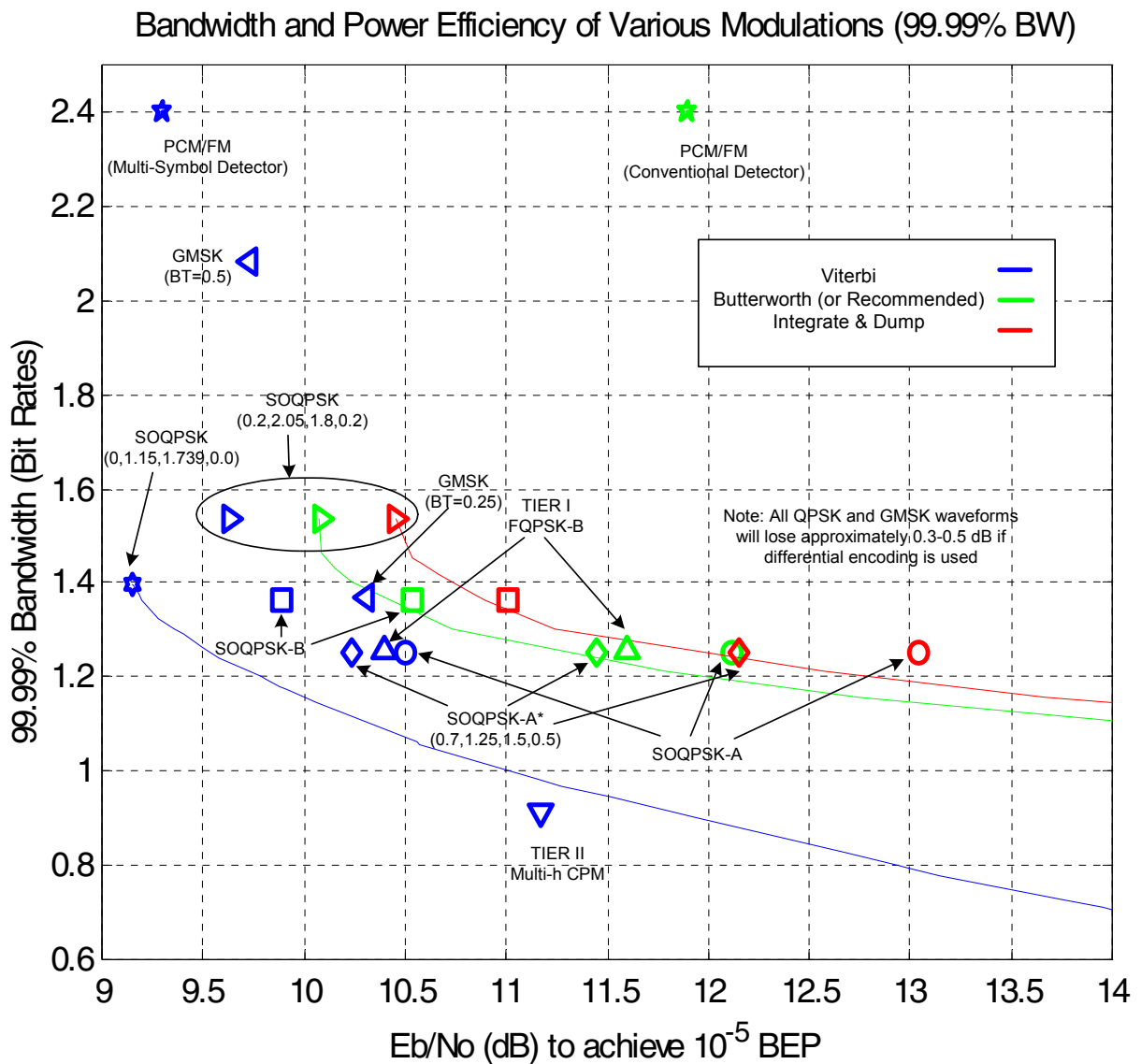

Figure 12. Bandwidth/Power Plane using 99.99% Bandwidth Measure with NLA

## CONCLUSIONS

Results illustrating the bandwidth and power efficiency of the SOQPSK family have been presented. It was shown that SOQPSK offers a wide range of performance trade-offs as seen from both the bandwidth efficiency plots and the listed performance of the particular members. Several interesting results can be concluded from the presented data. First, by examining the individual parameters,  $B$  seems to dominate the pulse shape for variants that only emphasize detection efficiency. However, as the bandwidth decreases, the parameter  $\rho$  begins to dominate resulting in a waveform with improved spectral efficiency. Second, the best performing members with a Viterbi detector generally perform poorly with linear detectors since it places no value on keeping an open 'eye' pattern that is critical for the operation of the linear detectors. Third, although the optimal Viterbi detector is more complex, it is much more tolerant of reductions in bandwidth than the linear detectors. In other words, the penalty in detection efficiency for reducing the bandwidth a fixed percentage is typically much less with the Viterbi detector.

These results show that SOQPSK is an attractive modulation choice with good performance and reasonable implementation complexity with certain variants being shown to outperform both GMSK and FQPSK-B. In summary, SOQPSK is a family of non-proprietary, constant envelope waveforms that have outstanding detection efficiency and spectral containment and are ideally suited for a variety of commercial and military applications.

## REFERENCES

1. T. Hill, "An Enhanced, Constant Envelope, Interoperable Shaped Offset QPSK (SOQPSK) Waveform for Improved Spectral Efficiency", Proceedings of the International Telemetry Conference, San Diego, CA, October 2000.
2. M. Geoghegan, "Implementation and Performance Results for Trellis Detection of SOQPSK", Proceedings of the International Telemetry Conference, Las Vegas, NV, October 2001.
3. B. Younes; J. Brase; C. Patel; J. Wesdock, "An Assessment of Shaped Offset QPSK for Use in NASA Space Network and Ground Network Systems", Meetings of Consultative Committee for Space Data Systems, Toulouse, France, October 2000.
4. K. Feher, R. Jefferis, E. Law, , "Spectral Efficiency and Adjacent Channel Interference Performance Definitions and Requirements for Telemetry Applications", Proceedings of the International Telemetry Conference, Las Vegas, NV, October 1999.
5. D. Lee, M. Simon, T.Y. Yan, "Enhanced Performance of FQPSK-B Receiver based on Trellis-Coded Viterbi Demodulation", Proceedings of the International Telemetry Conference, San Diego, CA, October 2000.
6. K. Murota, K.Hirade, , "GMSK Modulation for Digital Mobile Radio Telephony", IEEE Transactions Comm., Vol. COM-29,pp.1044-1050, July 1981.