

PROPRIETARY AND CONFIDENTIAL
 THE INFORMATION CONTAINED IN THIS DRAWING IS THE SOLE PROPERTY OF QUASONIX INC. ANY REPRODUCTION IN PART OR AS A WHOLE WITHOUT THE WRITTEN PERMISSION OF QUASONIX INC. IS PROHIBITED.

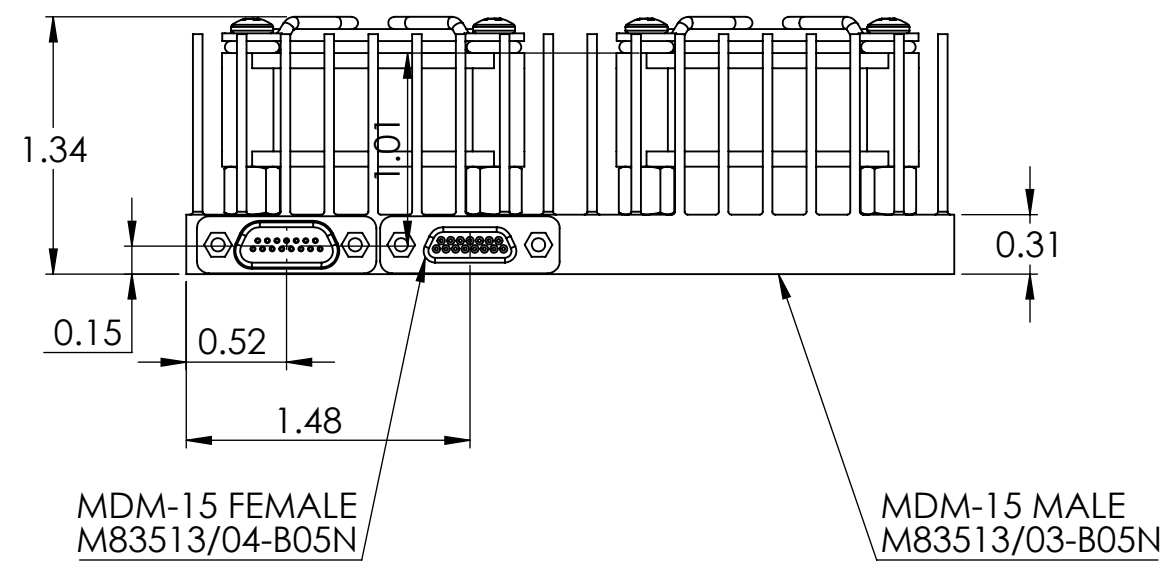
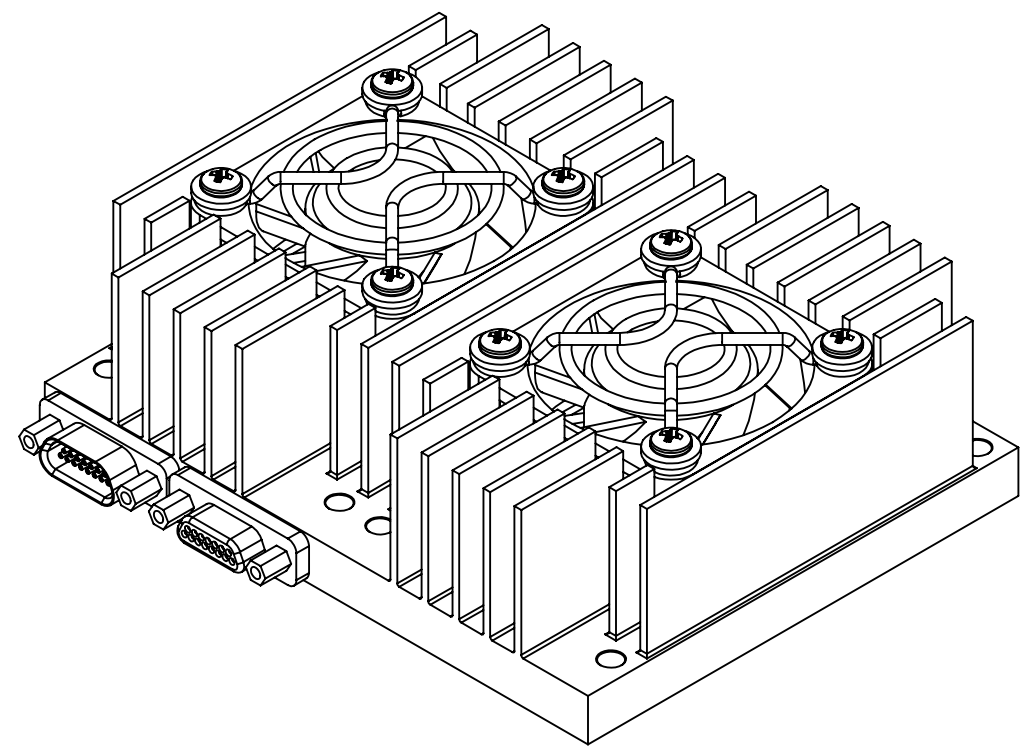
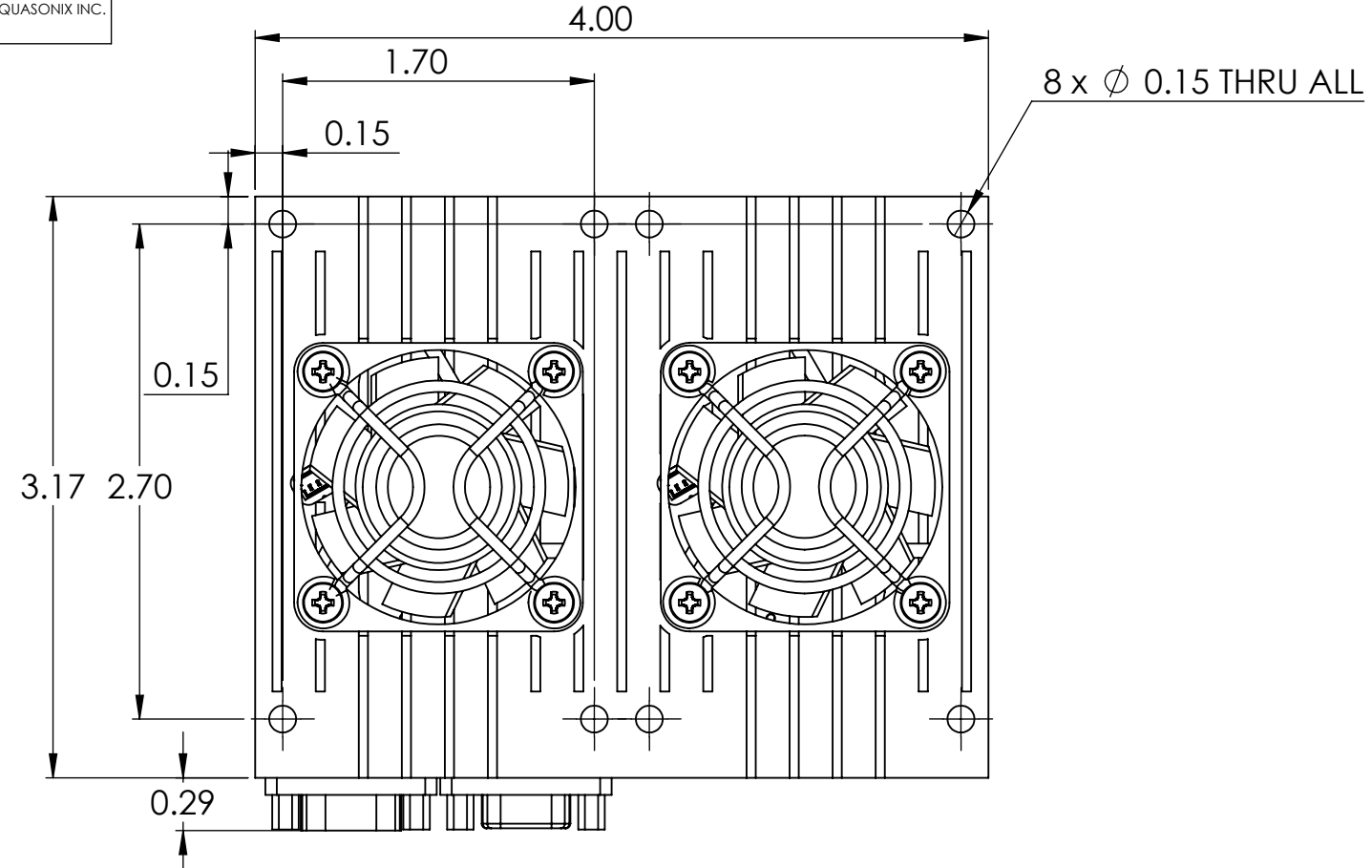

MOUNTING HARDWARE	TIGHTENING TORQUE	CLAMPING FORCE
#6	9.6 IN-LB +/- 10%	380 LB +/- 10%

UNLESS OTHERWISE SPECIFIED:
 DIMENSIONS ARE IN INCHES
 TOLERANCES ARE:
 ANGULAR: MACH/BEND ± .5°
 ONE PLACE DECIMAL ±0.1
 TWO PLACE DECIMAL ±0.03
 THREE PLACE DECIMAL ±0.010
 FRACTIONS ±1/32
 DO NOT SCALE DRAWING

	NAME	DATE
DRAWN	MBS	11/02/2023
ENG APPR.	MBS	11/02/2023
MATERIAL:		
FINISH:		

TITLE: QSX-AC-34-HS-28V-SP		
SIZE B	DWG. NO. QSX-AC-HS	REV
SCALE: 1:1	CAGE CODE: 3CJA9	SHEET 1 OF 2

PROPRIETARY AND CONFIDENTIAL
THE INFORMATION CONTAINED IN THIS DRAWING IS THE SOLE PROPERTY OF QUASONIX INC. ANY REPRODUCTION IN PART OR AS A WHOLE WITHOUT THE WRITTEN PERMISSION OF QUASONIX INC. IS PROHIBITED.

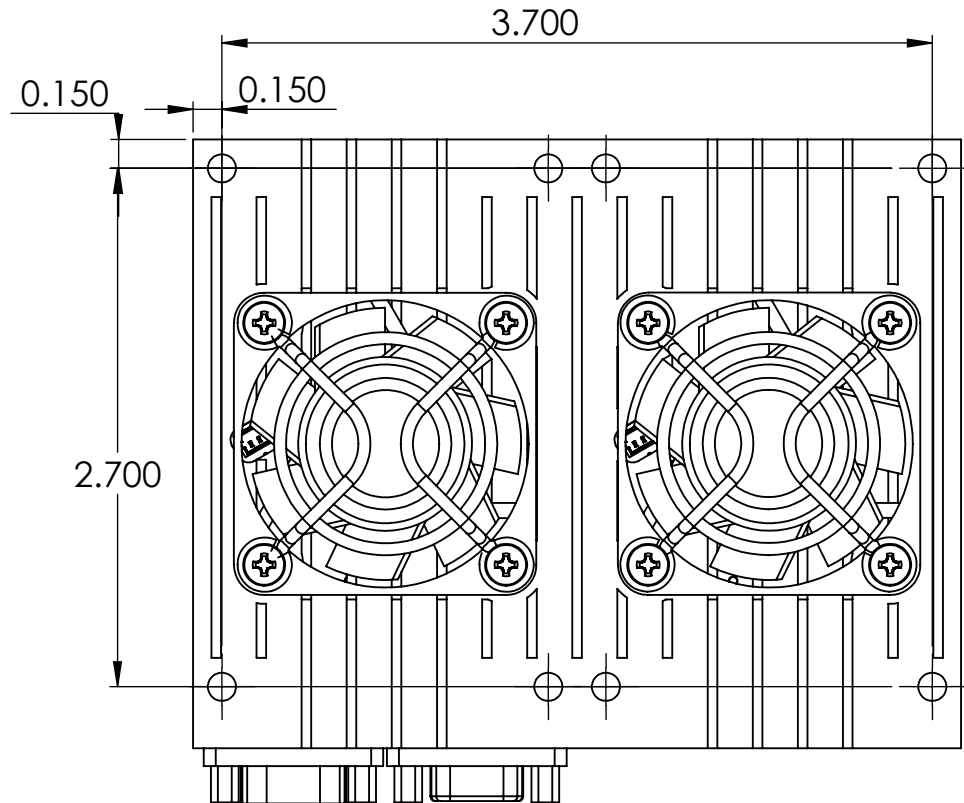

SIZE B	DWG. NO. QSX-AC-HS	REV
SCALE: 1:1	CAGE CODE: 3CJA9	SHEET 2 OF 2