

PROPRIETARY AND CONFIDENTIAL
 THE INFORMATION CONTAINED IN THIS DRAWING IS THE SOLE PROPERTY OF QUASONIX INC. ANY REPRODUCTION IN PART OR AS A WHOLE WITHOUT THE WRITTEN PERMISSION OF QUASONIX INC. IS PROHIBITED.

REVISION			
REV.	DESCRIPTION	DATE	APPROVED
X1	INITIAL RELEASE	3/20/2023	DT

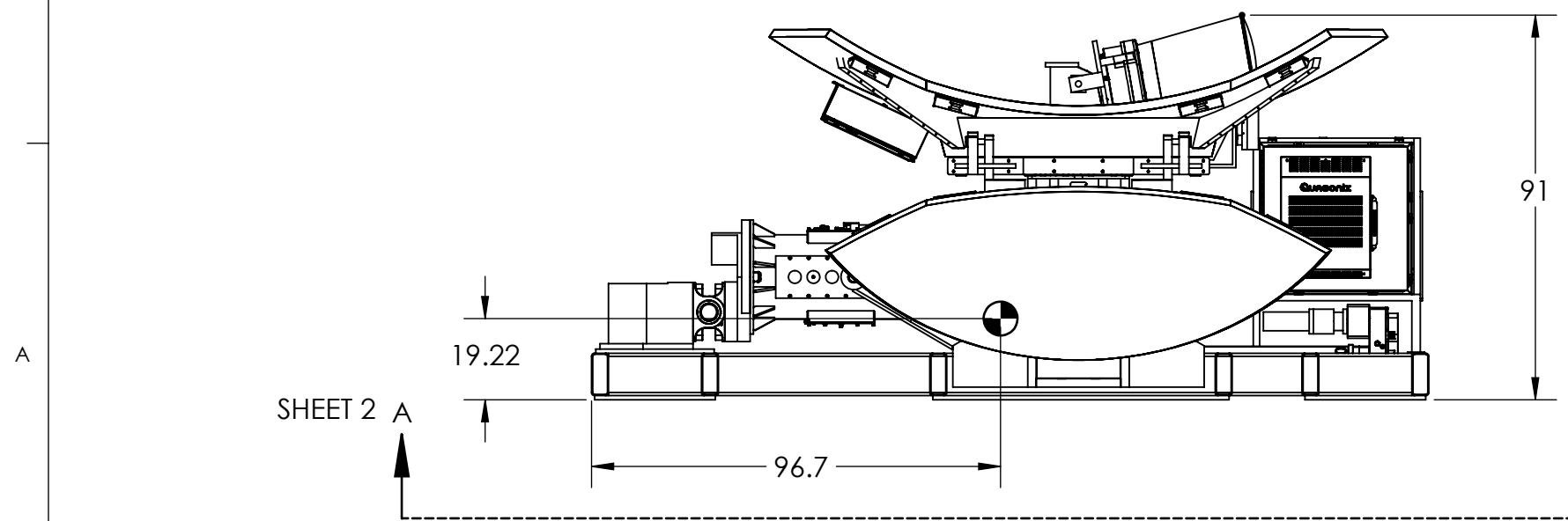
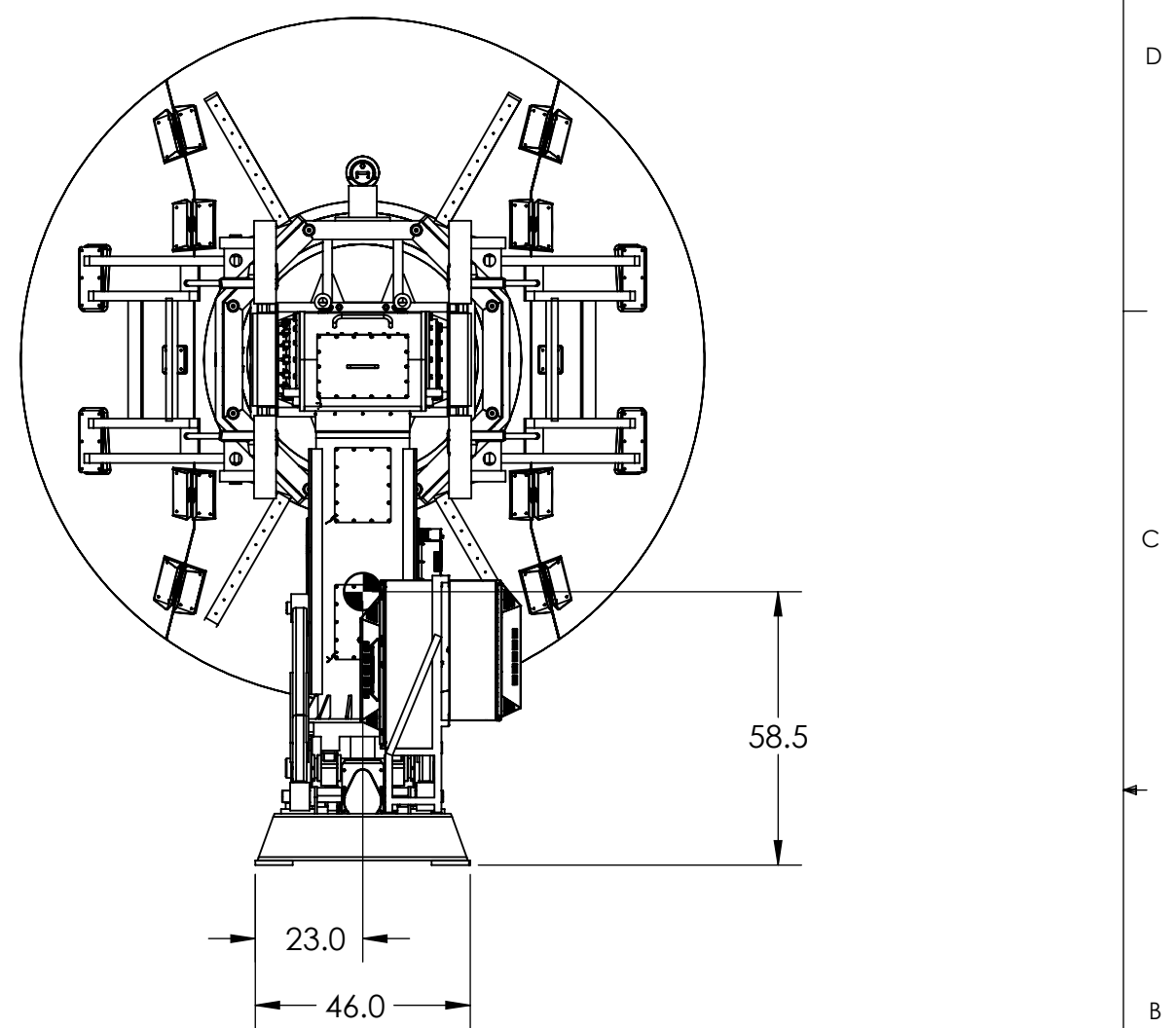
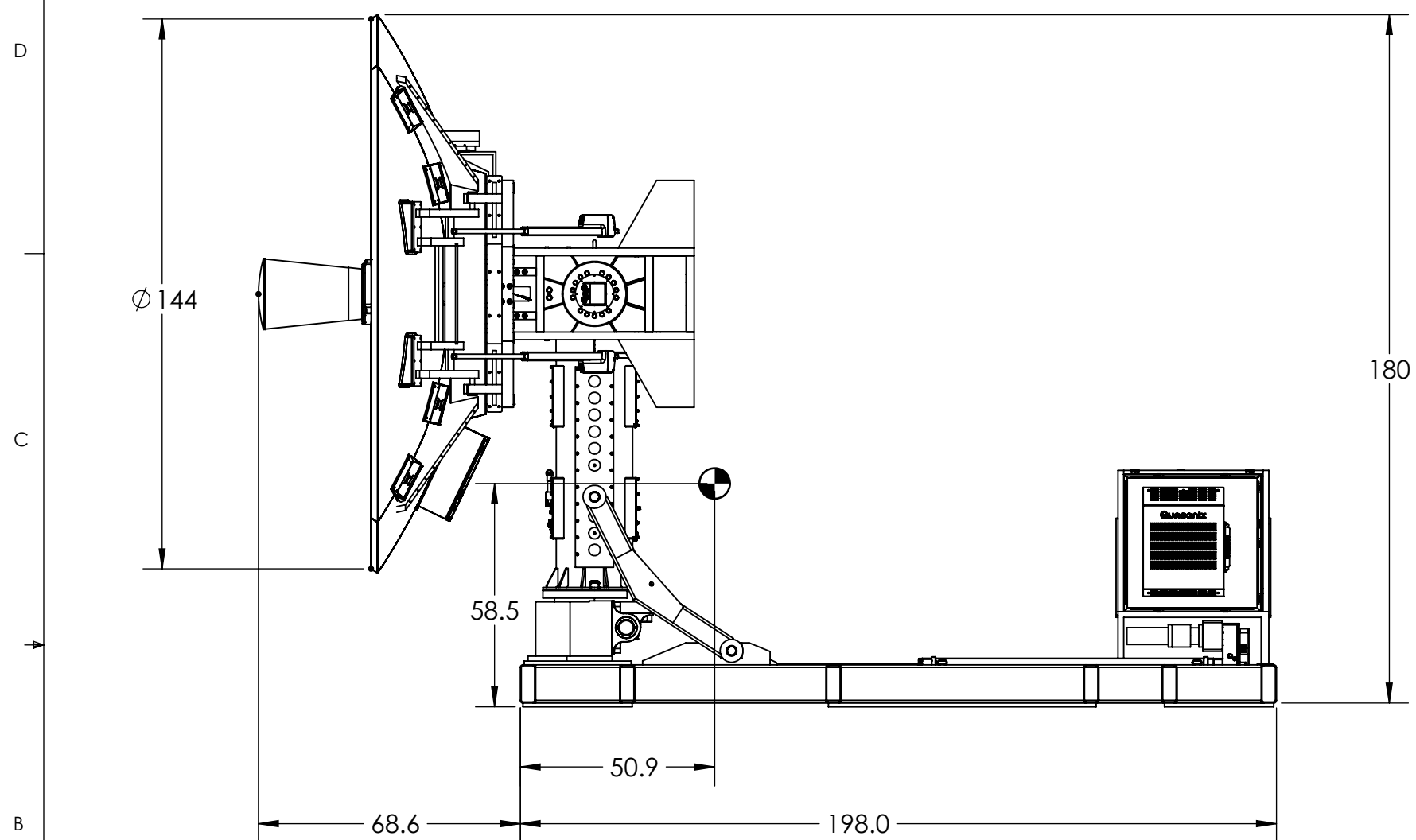

WEIGHT: 10,500 LBS ESTIMATED

UNLESS OTHERWISE SPECIFIED:
 DIMENSIONS ARE IN INCHES
 TOLERANCES ARE:
 ANGULAR: MACH ±1 BEND ±1
 ONE PLACE DECIMAL ±0.1
 TWO PLACE DECIMAL ±0.01
 THREE PLACE DECIMAL ±0.003
 FRACTIONS ±1/32
 DO NOT SCALE DRAWING

HOLE DIA.	TOLERANCE
.0135 THRU .125	+ .004 - .001
.126 THRU .250	+ .005 - .001
.251 THRU .500	+ .006 - .001
.501 THRU .750	+ .008 - .001
.751 THRU 1.000	+ .010 - .001
1.001 THRU 2.000	+ .012 - .001

	NAME	DATE
DRAWN	DT	12/17/2023
ENG APPR.		
MATERIAL:	*	
FINISH:	*	

QUASONIX

TITLE: ANTENNA /PEDESTAL INTERFACE CONTROL DOCUMENT

SIZE B	DWG. NO. 752740001-01	REV X1
SCALE: 1:100	CAGE CODE: 3CJA9	SHEET 1 OF 3

PROPRIETARY AND CONFIDENTIAL
 THE INFORMATION CONTAINED IN THIS DRAWING IS THE SOLE PROPERTY OF QUASONIX INC. ANY REPRODUCTION IN PART OR AS A WHOLE WITHOUT THE WRITTEN PERMISSION OF QUASONIX INC. IS PROHIBITED.

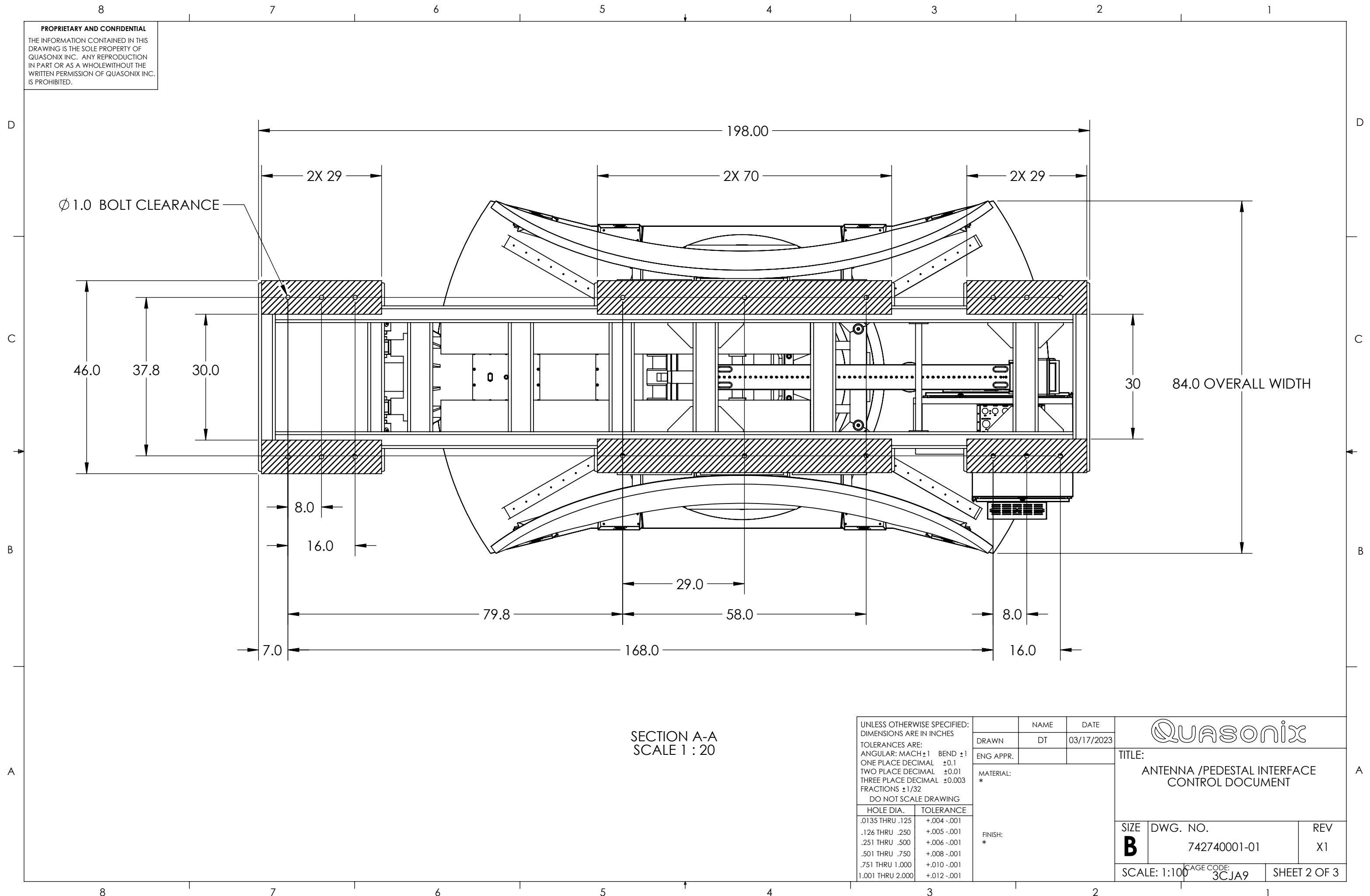

SECTION A-A
 SCALE 1 : 20

UNLESS OTHERWISE SPECIFIED:
 DIMENSIONS ARE IN INCHES
 TOLERANCES ARE:
 ANGULAR: MACH ±1 BEND ±1
 ONE PLACE DECIMAL ±0.1
 TWO PLACE DECIMAL ±0.01
 THREE PLACE DECIMAL ±0.003
 FRACTIONS ±1/32
 DO NOT SCALE DRAWING

HOLE DIA.	TOLERANCE
.0135 THRU .125	+ .004 - .001
.126 THRU .250	+ .005 - .001
.251 THRU .500	+ .006 - .001
.501 THRU .750	+ .008 - .001
.751 THRU 1.000	+ .010 - .001
1.001 THRU 2.000	+ .012 - .001

	NAME	DATE
DRAWN	DT	03/17/2023
ENG APPR.		
MATERIAL:	*	
FINISH:	*	

Quasonix

TITLE:
 ANTENNA /PEDESTAL INTERFACE
 CONTROL DOCUMENT

SIZE	DWG. NO.	REV
B	742740001-01	X1
SCALE: 1:100	CAGE CODE: 3CJA9	SHEET 2 OF 3

PROPRIETARY AND CONFIDENTIAL
 THE INFORMATION CONTAINED IN THIS DRAWING IS THE SOLE PROPERTY OF QUASONIX INC. ANY REPRODUCTION IN PART OR AS A WHOLE WITHOUT THE WRITTEN PERMISSION OF QUASONIX INC. IS PROHIBITED.

REFLECTOR POSITION ACTUATOR SUB ASSEMBLY

ANTENNA ARTICULATION CONTROL ENCLOSURE

ANTENNA TELEMETRY CONTROL ENCLOSURE

REFLECTOR POSITION ACTUATOR SUB ASSEMBLY

Ø 186 SWEEP AREA

PEDESTAL LIFT SUB ASSEMBLY

SECTION C-C
 SCALE 1 : 40

UNLESS OTHERWISE SPECIFIED:
 DIMENSIONS ARE IN INCHES
 TOLERANCES ARE:
 ANGULAR: MACH ±1 BEND ±1
 ONE PLACE DECIMAL ±0.1
 TWO PLACE DECIMAL ±0.01
 THREE PLACE DECIMAL ±0.003
 FRACTIONS ±1/32
 DO NOT SCALE DRAWING

HOLE DIA.	TOLERANCE
.0135 THRU .125	+.004 -.001
.126 THRU .250	+.005 -.001
.251 THRU .500	+.006 -.001
.501 THRU .750	+.008 -.001
.751 THRU 1.000	+.010 -.001
1.001 THRU 2.000	+.012 -.001

NAME	DATE
DT	03/17/2023

ENG APPR.
 MATERIAL:
 *

FINISH:
 *

QUASONIX

TITLE:
 ANTENNA /PEDESTAL INTERFACE
 CONTROL DOCUMENT

SIZE	DWG. NO.	REV
B	75274000-01	X1

SCALE: 1:96 CAGE CODE: 3CJA9 SHEET 3 OF 3

