

## MULTI-MODE TELEMETRY TRANSMITTERS

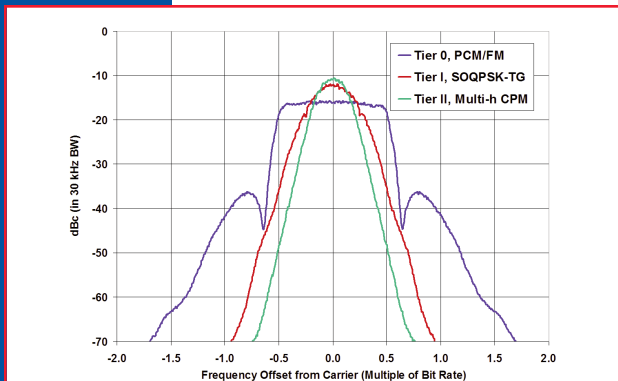

- **PCM/FM, SOQPSK-TG, and ARTM CPM Modulations Available**

Supports ARTM Tier 0 (PCM/FM) legacy waveform as well as the more spectrally-efficient Tier I (SOQPSK-TG) and Tier II (ARTM CPM) waveforms.

- **Output Power from 10 mW to 20 W**

Several RF output choices, along with variable power and dual power options for software- or hardware-based power adjustment.

- **Exceptional DC-to-RF Conversion Efficiency**

Draws less current than other telemetry transmitters, at any RF output level.

- **Tri-Band TIMTER Available**

One-size-fits-all solution available with all three legacy TM bands: lower L, upper L, and full S.

- **C-Band TIMTER Available**

New C-band TIMTER supports migration to the 4400-4950 MHz and 5091-5150 MHz frequency bands.

- **Smallest ARTM Transmitter Now Available**

Brand-new 1.3 in<sup>3</sup> nanoTX™ transmitter ideal for airborne applications with strict SWAP constraints.

- **3rd Generation TIMTER Now Available**

At less than 0.7 inches tall, new 4.1 in<sup>3</sup> TIMTER™ transmitter can serve as a drop-in replacement for common 0.8 inch-tall transmitters in the market.

- **Automatic Data Rate Tracking**

Premod filtering and deviation automatically track the data rate, with no programming or configuration required.

- **Clock-Free Input Option Available**

Ideal for replacing analog transmitters or for use with encoders or cryptos that provide a data output only.



# TRANSMITTER SPECIFICATIONS:

Characteristic	Specification
<b>Main Section</b>	
Modulation type	PCM/FM (ARTM Tier 0) SOQPSK-TG (Tier I) ARTM CPM (Tier II)
Carrier frequency tuning range	All models: 1435.5 - 1534.5 MHz (Lower-L band) 1750.0 - 1855.0 MHz (Upper-L, "U", band) 2200.5 - 2394.5 MHz (S band) TIMTER model only: 1435.5 - 1534.5 MHz, 1750.0 - 1855.0 MHz, 2200.5 - 2394.5 MHz ("Tri band") 4400.0 - 4950.0 MHz (C band "low," standard) 5091.0 - 5150.0 MHz (C band "mid," optional)
RF output power	TIMTER L, U, S bands: 10 mW, 5 W, 10 W, 20 W TIMTER C band: 10 mW, 5 W, 10 W TIMTER Tri band: 20 mW, 5 W, 10 W nanoTX: 1 W, 2 W, or 5 W  <i>Option DP:</i> Dual power, 2 settings, via baseband connector pin <i>Option VP:</i> Variable power, 31 settings over 24 dB range via PC (non-uniform, largest step approximately 1 dB)
Carrier frequency tuning increment	0.5 MHz
Carrier frequency accuracy	± 2.5 ppm over temperature ± 7.5 ppm, all causes, including aging over 5 years
Data (bit) rate, automatic rate adaptation	TIMTER: 1-20 Mbps (0.5-10 Mbps for PCM/FM) TIMTER <i>option HR:</i> Extends upper limit to 28 Mbps (14 Mbps for PCM/FM) TIMTER <i>option LR:</i> Extends lower limit to 50 kbps (25 kbps for PCM/FM) nanoTX: 1-28 Mbps (0.5-14 Mbps for PCM/FM)
Input voltage	TIMTER: +28 ± 4 VDC ( <i>optional wide voltage +21 to +34 VDC</i> ) nanoTX: +6 to +32 VDC for 1 and 2 Watt versions, +12 to +32 VDC for 5 Watt version ( <i>optional wide voltage +12 to +34 VDC</i> )
Input current @ +28 VDC	TIMTER Single band, 5 Watt: 1.2 A max; 1.0 A typical TIMTER Single band, 10 Watt: 1.8 A max; 1.5 A typical TIMTER Single band, 20 Watt: 3.0 A max; 2.8 A typical TIMTER Tri band, 5 Watt: 1.8 A max; 1.3 A typical TIMTER Tri band, 10 Watt: 2.5 A max; 1.8 A typical nanoTX 1 Watt: 400 mA max; 350 mA typical nanoTX 2 Watt: 570 mA max; 480 mA typical nanoTX 5 Watt: 1000 mA max; 850 mA typical
Power reversal	Reverse voltage protection
Control interface	RS-232 serial control
Signal interfaces	Serial data with separate synchronous clock, TTL or TIA/EIA-422 (RS-422)
Randomizer	15-stage LFSR, per IRIG 106. Selectable for bypass or enable
<b>Environmental Section</b>	
Operating temperature	-40°C to +85°C (10 mW, 5 W, 10 W models) -40°C to +70°C (20 W model)
Non-operating temperature	-40°C to +85°C (all models)
Operating humidity	0 to 95% (non-condensing)
Altitude	Up to 100,000 ft.



# TRANSMITTER SPECIFICATIONS:

Characteristic	Specification
<b>Physical Section</b>	
Size / weight	TIMTER 4C / 4D package: 4.1 in <sup>3</sup> , 2.000" (W) x 3.000" (L) x 0.688" (H) / 4.2 oz. TIMTER 6B / 6C package: 6.0 in <sup>3</sup> , 2.000" (W) x 3.000" (L) x 1.000" (H) / 6.5 oz. nanoTX 1A / 1B package: 1.3 in <sup>3</sup> , 1.250" (W) x 3.400" (L) x 0.300" (H) / 1.3 oz.
Vibration	19.6 G random, 20 Hz to 2,000 Hz, 3 axes
Shock	60 G, 1/2 sine, 5 mS duration, 3 axes
Acceleration	100 G, 3 axes
Connector – RF	TIMTER: SMA female nanoTX: MMCX
Connector – Baseband / Primary	TIMTER: MDM-15 (male for TTL, female for RS-422) nanoTX 1A: 15-pin Nano-D female nanoTX 1B: 21-pin Nano-D female (required for RS-422)
Connector – Miscellaneous	TIMTER 6B: MDM-9 (parallel port for Quasonix switch box programming) TIMTER 6C: MDM-15 (parallel port for BCD programming) TIMTER 4C: SSMA female (analog modulation input)

## MODEL NUMBERS:

Q S X - V - - - S - 2 0 - - -

Band: **L** for Lower L, **U** for Upper L, **S, M** for Tri-band, or **C**

Baseband Interface: **T** = TTL, **R** = RS-422

PCM/FM: **1** = Include, **0** = Exclude

SOQPSK-TG: **1** or **0**

ARTM CPM: **1** or **0**

Power: **00** = 10 mW, **01** = 1 W, **02** = 2 W, **05** = 5 W, **10** = 10 W, or **20** = 20 W

Package: **4D** = TIMTER, **4C** = TIMTER w/ analog modulation input, **6B** = TIMTER w/ 9-pin parallel port,

**6C** = TIMTER w/ 15-pin parallel port, **1A** = nanoTX w/ 15-pin connector,

**1B** = nanoTX w/ 21-pin connector

Options (separate multiple options by a dash, "-")

Note: Certain model number combinations are not possible. Please consult factory for availability.

## OPTIONAL FEATURES:

- > PS Multiple presets (2, 4, 8, or 16; concatenate to "PS")
- > WV Wide input voltage range
- > CG Clock generator output to baseband connector
- > RN Randomizer output to baseband connector
- > DP Dual power (two settings, "high" and "low")
- > AC Automatic carrier wave output
- > RG Reverse gender option for baseband connector
- > VR Variable reference level inputs (RS-422 and TTL)
- > CM C-band "mid" coverage (5091.0 - 5150.0 MHz)
- > VP Variable power (31 settings, spanning 24 dB)
- > CF Clock-free baseband interface
- > HR Increases max bit rate to 28 Mbps (14 Mbps for Tier 0)
- > LR Decreases min bit rate to 50 kbps (25 kbps for Tier 0)
- > LD FEC / Low Density Parity Check (LDPC)
- > EC FEC / Turbo Product Codes (TPC)
- > PF Parallel port frequency programming
- > PM Parallel port mode selection



## TRANSMITTER ACCESSORIES:

- **Handheld Programmer** (P/N: QSX-AC-HHPRG-800N-Y)  
*Ruggedized and waterproof TDS Nomad Pocket PC with custom Quasonix user interface for convenient in-field programming via RS-232 control interface.*
- **Adapter Plate** (P/N: QSX-AC-AP96)  
*Adapts the 2" x 3" TIMTER transmitter footprint to a larger 2.5" x 3.5" mounting footprint.*
- **Fan-Cooled Heat Sink** (P/N: QSX-AC-32-HS-12V)  
*Heat sink with fan for TIMTER model. Includes wall wart power supply for North American operation. Pictured with transmitter attached and rubber feet (not included).*
- **MDM-15 Connector & Pigtails** (P/N: QSX-AC-MDM15-36-PIN or QSX-AC-MDM15-36-SOCK)  
*Mating connector prewired with 36" non-terminated, color-coded pigtail cables for transmitter connections. Pin connector required for standard RS-422 transmitters, socket connector for standard TTL transmitters.*
- **MDM-15 Wiring Harness** (P/N: QSX-AC-MDM15-HARNESS-PIN or QSX-AC-MDM15-HARNESS-SOCK)  
*Mating connector prewired and terminated with BNC connectors for clock and data, banana plugs for power and ground, and a DB-9 connector for serial control. Pin connector required for standard RS-422 transmitters, socket connector for standard TTL transmitters.*
- **Switch Box for Parallel Port Frequency and Mode Programming Options** (P/N: QSX-AC-SWBX-3B-3M)  
*Small aluminum switch box for use with transmitters equipped with the 9-pin parallel port (6B package). Provides frequency and mode programming capability.*
- **USB to Serial Adapter** (P/N: QSX-AC-USBSER-CONV)  
*Converts USB interface to serial interface for controlling transmitters from a PC that does not have a DB-9 connector.*



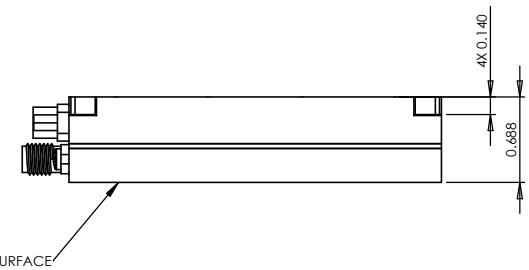
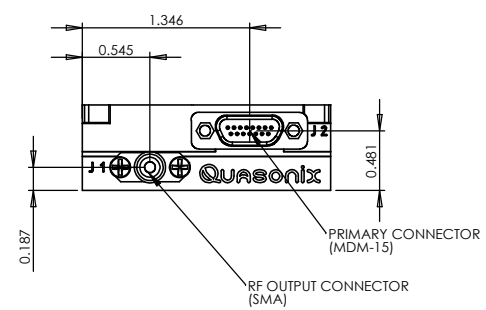
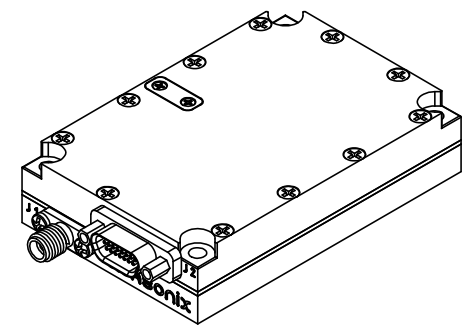
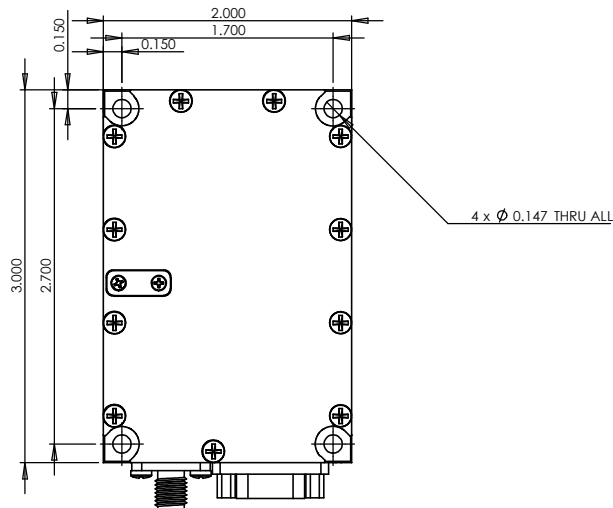

**PROPRIETARY AND CONFIDENTIAL**  
 THE INFORMATION CONTAINED IN THIS DRAWING IS THE SOLE PROPERTY OF QUASONIX, LLC. ANY REPRODUCTION IN PART OR AS A WHOLE WITHOUT THE WRITTEN PERMISSION OF QUASONIX, LLC IS PROHIBITED.

		UNLESS OTHERWISE SPECIFIED:		NAME	DATE		
		DIMENSIONS ARE IN INCHES		DRAWN	BJH		
		TOLERANCES:		CHECKED			TITLE: TIMTER PACKAGE CODE 4D
		ANGULAR: MACH ±1 BEND ±1		ENG APPR.			
		TWO PLACE DECIMAL ±0.01		MFG APPR.			
		THREE PLACE DECIMAL ±0.003		Q.A.			SIZE <b>B</b>
		INTERPRET GEOMETRIC TOLERANCING PER:		COMMENTS:			DWG. NO.
		MATERIAL					REV
		FINISH					
NEXT ASSY	USED ON						SCALE: 1:1
APPLICATION							WEIGHT:
							SHEET 6 OF 12

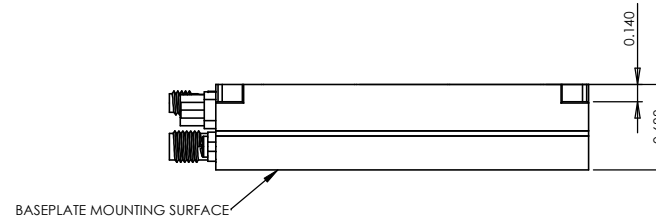
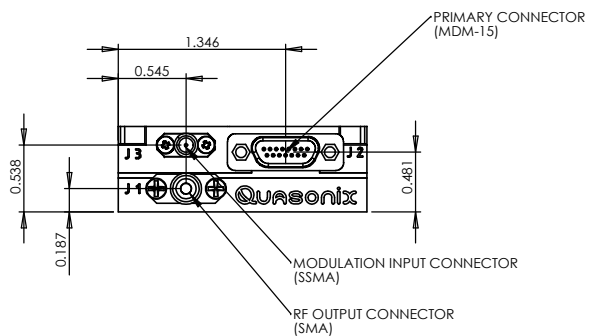
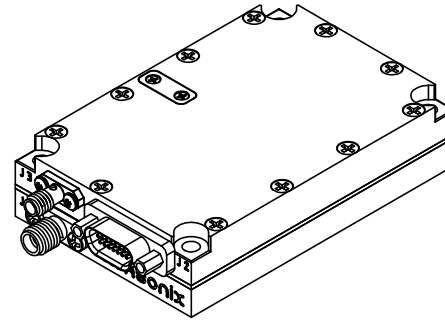
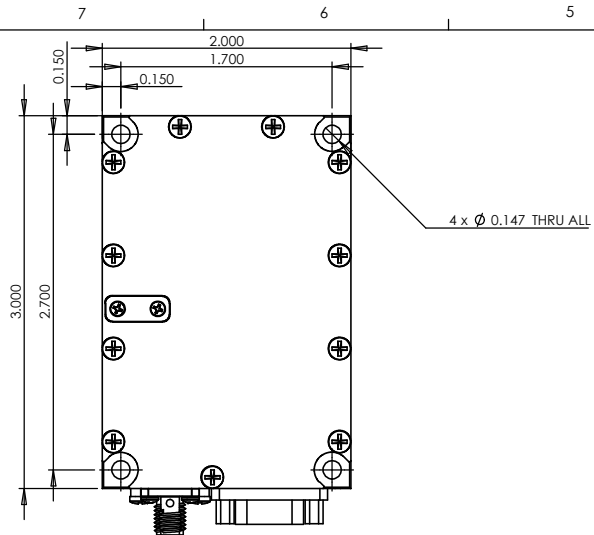

**PROPRIETARY AND CONFIDENTIAL**  
THE INFORMATION CONTAINED IN THIS DRAWING IS THE SOLE PROPERTY OF QUASONIX, LLC. ANY REPRODUCTION IN PART OR AS A WHOLE WITHOUT THE WRITTEN PERMISSION OF QUASONIX, LLC IS PROHIBITED.

		UNLESS OTHERWISE SPECIFIED:		NAME	DATE	
		DIMENSIONS ARE IN INCHES TOLERANCES: ANGULAR: MACH ±1 BEND ±1 TWO PLACE DECIMAL ±0.01 THREE PLACE DECIMAL ±0.003		DRAWN	2/24/10	
		INTERPRET GEOMETRIC TOLERANCING PER:		CHECKED		TIMTER PACKAGE CODE 4C
		MATERIAL		ENG APPR.		
		FINISH		MFG APPR.		
		NEXT ASSY		Q.A.		
		USED ON		COMMENTS:		SIZE
		APPLICATION				<b>B</b>
						DWG. NO.
						REV
						SCALE: 1:1
						WEIGHT:
						SHEET 5 OF 12

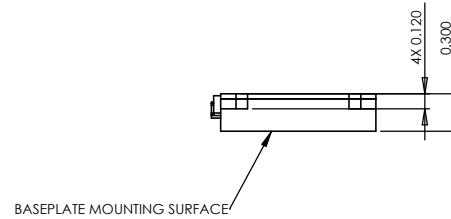
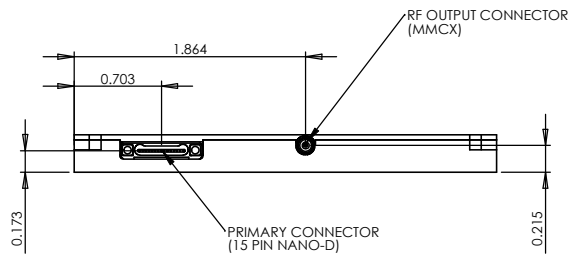
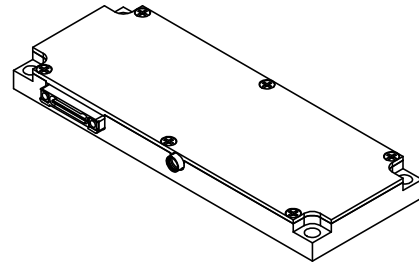
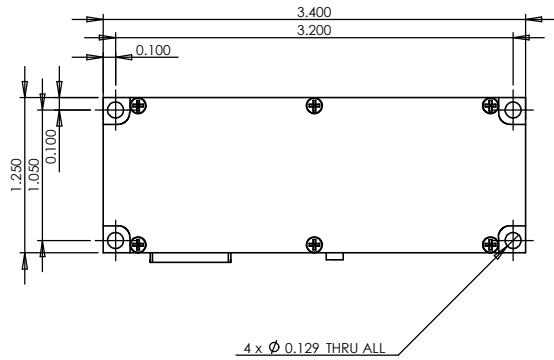

**PROPRIETARY AND CONFIDENTIAL**  
 THE INFORMATION CONTAINED IN THIS DRAWING IS THE SOLE PROPERTY OF QUASONIX, LLC. ANY REPRODUCTION IN PART OR AS A WHOLE WITHOUT THE WRITTEN PERMISSION OF QUASONIX, LLC IS PROHIBITED.

		UNLESS OTHERWISE SPECIFIED:		NAME	DATE	 <b>Quasonix</b>	
		DIMENSIONS ARE IN INCHES		DRAWN	NFE		
		TOLERANCES:		CHECKED			TITLE:
		ANGULAR: MACH ±1 BEND ±1		ENG APPR.			nanoTX PACKAGE CODE 1A
		TWO PLACE DECIMAL ±0.01		MFG APPR.			SIZE
		THREE PLACE DECIMAL ±0.003		Q.A.			<b>B</b>
		INTERPRET GEOMETRIC TOLERANCING PER:		COMMENTS:			DWG. NO.
		MATERIAL					REV
		FINISH					SCALE: 1:1
NEXT ASSY	USED ON						WEIGHT:
APPLICATION							SHEET 1 OF 12

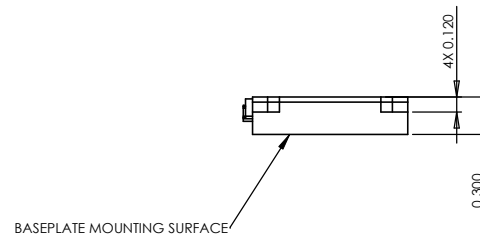
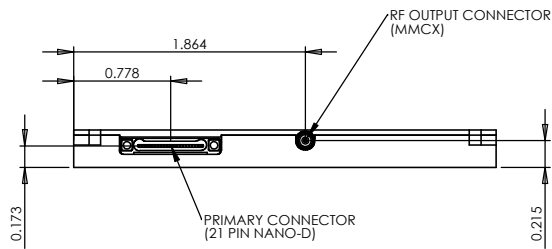
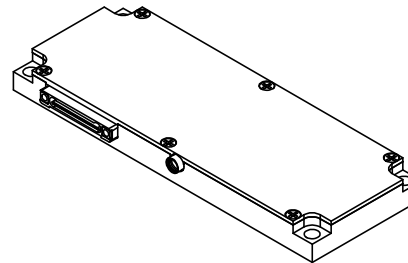
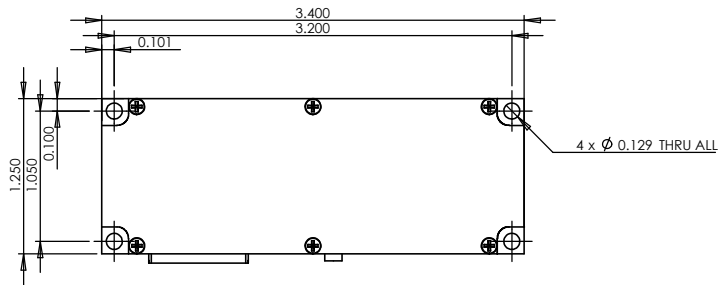

**PROPRIETARY AND CONFIDENTIAL**  
THE INFORMATION CONTAINED IN THIS DRAWING IS THE SOLE PROPERTY OF QUASONIX, LLC. ANY REPRODUCTION IN PART OR AS A WHOLE WITHOUT THE WRITTEN PERMISSION OF QUASONIX, LLC IS PROHIBITED.

		UNLESS OTHERWISE SPECIFIED:		NAME	DATE	 <b>Quasonix</b>	
		DIMENSIONS ARE IN INCHES		DRAWN	NFE		
		TOLERANCES:		CHECKED		TITLE:	
		ANGULAR: MACH $\pm$ 1 BEND $\pm$ 1		ENG APPR.		nanoTX PACKAGE CODE 1B	
		TWO PLACE DECIMAL $\pm$ 0.01		MFG APPR.		SIZE	
		THREE PLACE DECIMAL $\pm$ 0.003		Q.A.		<b>B</b>	
		INTERPRET GEOMETRIC TOLERANCING PER:		COMMENTS:		DWG. NO.	
		MATERIAL				REV	
NEXT ASSY		USED ON				SCALE: 1:1	
APPLICATION						WEIGHT:	
						SHEET 2 OF 12	

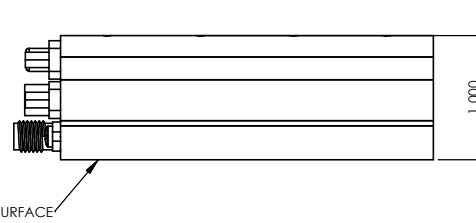
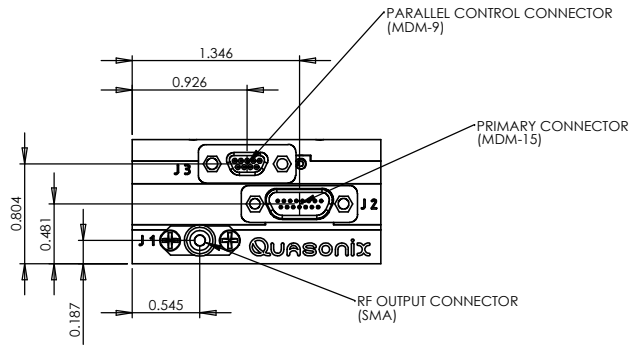
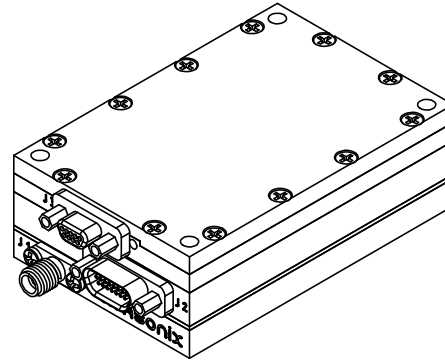
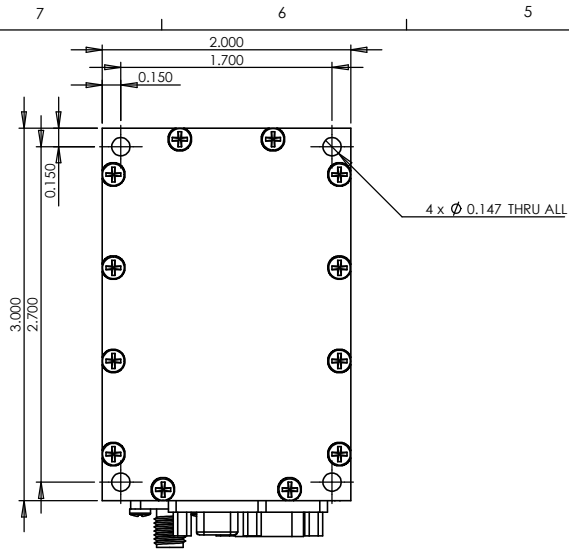

**PROPRIETARY AND CONFIDENTIAL**  
THE INFORMATION CONTAINED IN THIS DRAWING IS THE SOLE PROPERTY OF QUASONIX, LLC. ANY REPRODUCTION IN PART OR AS A WHOLE WITHOUT THE WRITTEN PERMISSION OF QUASONIX, LLC IS PROHIBITED.

		UNLESS OTHERWISE SPECIFIED:		NAME		DATE			
		DIMENSIONS ARE IN INCHES		DRAWN		BJH			
		TOLERANCES:		CHECKED				TITLE:	
		ANGULAR: MACH ±1 BEND ±1		ENG APPR.				TIMTER PACKAGE CODE 6B	
		TWO PLACE DECIMAL ±0.01		MFG APPR.				SIZE	
		THREE PLACE DECIMAL ±0.003		Q.A.				<b>B</b>	
		INTERPRET GEOMETRIC TOLERANCING PER:		COMMENTS:				DWG. NO.	
		MATERIAL						REV	
NEXT ASSY		USED ON						SCALE: 1:1	
APPLICATION								WEIGHT:	
								SHEET 9 OF 12	

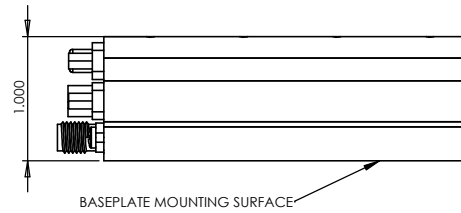
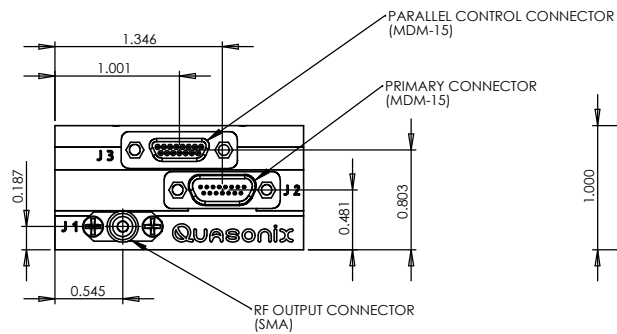
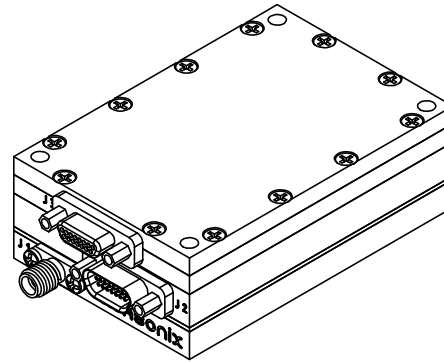
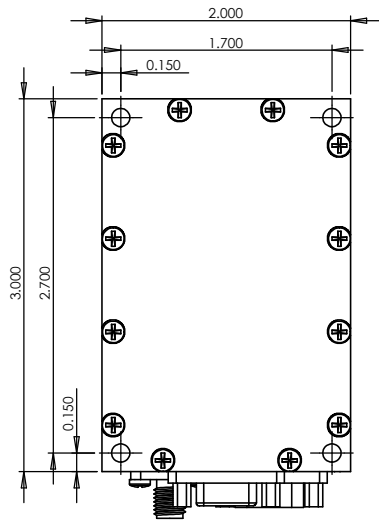

**PROPRIETARY AND CONFIDENTIAL**  
 THE INFORMATION CONTAINED IN THIS DRAWING IS THE SOLE PROPERTY OF QUASONIX, LLC. ANY REPRODUCTION IN PART OR AS A WHOLE WITHOUT THE WRITTEN PERMISSION OF QUASONIX, LLC IS PROHIBITED.

		UNLESS OTHERWISE SPECIFIED:		NAME	DATE		
		DIMENSIONS ARE IN INCHES		DRAWN	BJH		
		TOLERANCES:		CHECKED			TITLE: TIMTR PACKAGE CODE 6C
		ANGULAR: MACH $\pm 1$ BEND $\pm 1$		ENG APPR.			
		TWO PLACE DECIMAL $\pm 0.01$		MFG APPR.			
		THREE PLACE DECIMAL $\pm 0.003$		Q.A.			SIZE <b>B</b>
		INTERPRET GEOMETRIC TOLERANCING PER:		COMMENTS:			
		MATERIAL					DWG. NO.
		FINISH					REV
NEXT ASSY	USED ON						
APPLICATION							
							SCALE: 1:1
							WEIGHT:
							SHEET 13 OF 14